



A journey from the past into the future of WECO

100TH ANNIVERSARY SPECIAL EDITION



1921 • 2021

**A journey from the past
into the future of WECO**

100TH ANNIVERSARY SPECIAL EDITION



GESICHERTE MANTELKLEMMEN
gegen Lockern durch Sperrkräfte gesichert
für Schiffsbau, Flugzeugbau u. a.

Typ „MU-Sp“

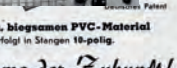
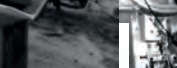

GESICHERTE MANTELKLEMME
mit deppantem Federling zur Vermeidung in
abblödfen- u. malströmigen Überleit. Betrieben

Typ „DF“



Die Klemme der Zukunft!
aus elastischem, biegsamen PVC-Material
Lieferung erfolgt in Stangen 10-polig.

1 Für alle Abzweigverbindungen in Unterputz-Dosen und
für Leuchten-Steckdosen

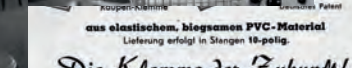
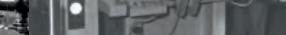
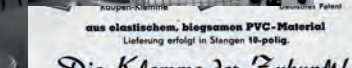
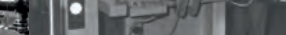

PROUD TO BE PART OF A CENTENARY COMPANY



Michel Alary
President & CEO

WECO's 100th Anniversary. What an amazing accomplishment, as few companies can honestly say they achieved. We and our products enable the world to get connected through our innovative electric connection solutions.

I joined WECO in 2012, more than nine years ago. I remember how I was welcomed back then, as if the company was a big family. That feeling never went away. This is the story of WECO. The story of a real family!

Since then, I was lucky enough to discover an organization with plenty of beautiful stories. Stories of success, challenges, transformation, and resilience as it takes resilience to operate in our highly competitive environment for 100 years.

This is due to the hard work and dedication of our innovators, engineers, dedicated employees, and suppliers. Our loyal customers and partners keep coming back to our reliable products that keep their operations running. All through our creative solutions, operating excellence and customer service are top priorities.

Our products were used and are still used in multiple industries that keep society running, such as medical or pharmaceutical, which are industries we now need more than ever.

With more than one thousand products in our portfolio, we never run out of brilliant ideas. Which have shaped the renewable energy market in all climates. We are part of this legacy.

As a group, we will continue to connect globally for another century. For our customers, we will continue to use our success and passion to exceed their expectations in creativity and high quality standards of products and services. We will also keep building long-term sustainable partnerships.

Today I am extremely proud to be part of this organization because it still allows me, after all this time, to further develop my professional skills. Every day I work with extraordinary people from Montreal, Germany, Tunisia, Mexico, Brazil and Asia. Each organization constantly outperforms itself. This allows me to learn and better understand the different cultures that make up the richness and strength of our success.



Heiner Kammann
Chairman

My story with WECO began in 1979 when I was studying economics and marketing in Düsseldorf. I was introduced to WECO's CEO in Germany at that time, Mr. Walter Ebbinghaus. We liked each other immediately, and he offered me the opportunity of a lifetime. He asked me to go abroad to establish WECO in Canada. My wife Eva and I accepted the challenge, and with our first daughter Catherine, we crossed the ocean by ship and immigrated to Canada. For all my life, living in Canada has been my dream.

In 1981, I started as an employee. And in 2015, my family became the sole shareholder of all WECO facilities worldwide. So, from the beginning until today, this company has been the center of my life. WECO enriched my family's life and mine with joy, challenges, and fulfillment. This year I celebrate 40 years with WECO. And during these years I met thousands of people, learned a second language that opened many doors for me and for the company, and had an international experience. But today I can honestly say that the greatest gift I received at WECO was my dream of living in Canada and meeting very diverse people. These people shaped my view of the world; they made me appreciate its rich tapestry of humanity.

WECO gave me a purpose in life and deep respect for everyone I was fortunate enough to meet, work and break bread with. I thank everyone who helped me along the way. Greetings to all those who struggled with me for a better company and a bright future for WECO.

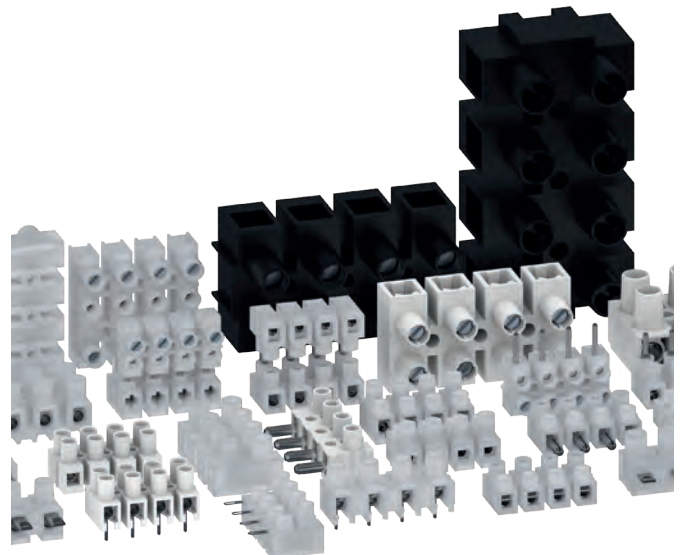

WECO INVITES YOU TO TRAVEL TOGETHER FOR 100 YEARS OF HISTORY AND CULTURE

The year of 2021 marks WECO's 100th anniversary. While we are incredibly proud of this achievement because few companies reach this significant milestone, we are humbled to remain one of the global leaders in this field of expertise.

It has been an exciting journey, made possible with the support of everyone, our dedicated employees, our partners, suppliers, and loyal customers. We enter the next 100 years with great pleasure.

To celebrate our anniversary, we will reveal the path taken by our founders, from WECO's humble beginnings with its first patent to operational excellence and innovative solutions and services. On the following pages, you will read about the key milestones and facts among WECO's achievements in each decade.

The campaign's concept initially aimed to create a commemorative logo to celebrate the 100th anniversary, highlighting the company's values and trajectory during these years and becoming a visual reference that connects with employees, partners, and customers.

Next, the 100th Anniversary campaign created a timeline with the pivotal moments and people who have been part of the company's history. The initial idea became a historical magazine to perpetuate the company's history for years to come.



In the commemorative logo, you can see explicit references to WECO's priorities. The creative design team took references from the company's journey to symbolize globalization, synergy, and key milestones. Trying to connect the company's past to its future, the symbols and photography used in the design represent the core values, solutions and stakeholders that were part of WECO's history.

Over the years, with technological revolutions and expanding markets, WECO expanded by building talented teams and reliable partnerships, in addition to establishing strategically located plants in Germany, Tunisia, and Canada.

WECO is presently a global company, headquartered in Montreal. Our presence in Asia-Pacific, Europe, Latin America, North Africa, and North America allows us to reach customers globally and provide efficient customer service.

Surviving a century was an endeavor WECO took on with perseverance, determination, and teamwork. We are proud to build high-quality products targeted at our customers on a global basis. Whether these are off-the-shelf regular products or customized to specific customer requirements, each item leaves WECO with the same attention to detail, always keeping the customer in mind.

It has been 100 years of implementing solid engineering solutions while collaborating with our customers' product evolution throughout the century! Accordingly, as a century-old company, we begin another chapter in our history.

By keeping our focus on our customers' new challenges, with social and environmental responsibility, our vision for the future is to be the first choice in customized electric connection solutions for industrial applications worldwide.



OUR VISION

WECO to be the first choice in tailored electrical connection solutions for industrial application worldwide.

OUR MISSION

We are committed to leverage our century of success and passion by exceeding customer expectations in creativity, high quality standards of products and service, and continue building sustainable long-term partnerships.

We offer expertise, superior agility and outstanding delivery performance.



OUR VALUES

- | | |
|----------------|------------------------|
| Customer Focus | Respect |
| Leadership | Communication |
| Accountability | Empowerment |
| Team Work | Continuous Improvement |

1920s

OUR history started in EUROPE but conquered the world. WECO was founded in Hanau, Germany, on the 21 of June in 1921. Famous for being the Grimm brothers' birthplace, the publishers of the well-loved fairy tales, this city is a port on the right bank of the canalized Main River at the Kinzig's southeast of Frankfurt.

Since the beginning, people have been the core of WECO. It started when two good friends; an engineer and an accountant combined their talents to solve a customer's need with their invention of a patent for jacket clamps. This early application was the beginning of success for WECO, an acronym for our founders' last names, Rudolf Wester Eugen Ebbinghaus and the word Company.

Eugen Ebbinghaus: Born 1873, in a small town in Germany, Eugen Ebbinghaus was an engineer who started the company based on his vision for business and operational excellence. He worked in the company for more than 41 years and then transferred the responsibility to his only child, Dr. Edgar Ebbinghaus in 1962.

Rudolf Wester: Rudolf Wester, an accountant from Germany, dedicated his entire life to build WECO as a strong and financially wealthy company. He retired from WECO after exceeding his goals.

Since the very beginning of our activities, our innovative ideas had one common need: connectivity. The company's founders Eugen Ebbinghaus and Rudolf Wester developed, patented, and manufactured a jacket clamp as a connecting element for electrical installations. This innovative idea and the

company's founding have marked the beginning of a success story.

WECO was the first connector company to use thermoplastics in the design and manufacturing of coupling and splicing connectors. Over the years we have developed exclusive connector designs for use in most industries, from switching and control panels used in power plants to controls used in manufacturing, automotive, and appliances. Our products are also present in petrochemical process plants, pharmaceutical, and computer technology.

In this chapter of WECO's history, you will learn more about a product that was essential to the company's initial activities: lighting. You will know how the technological journey has evolved until today, and how the past still inspires us to bring new ideas to life.

Looking back in time, British inventors were demonstrating that electric light was possible with the arc lamp. In 1835, the first constant electric light was demonstrated, and for the next 40 years, scientists around the world worked on the incandescent lamp up until Thomas Edison patented the first incandescent bulb in 1879 and commercialized it a year later.



WECO has made a major contribution to the field of lighting technology with its junction box terminals. With a patent issued in 1922, these metal mantle terminals were primarily valuable for securing power cables. The original design consisted of a ceramic base as an insulator, and screw terminals attached to the wire conductors. In addition, our proven and highly reliable design is still in use today.

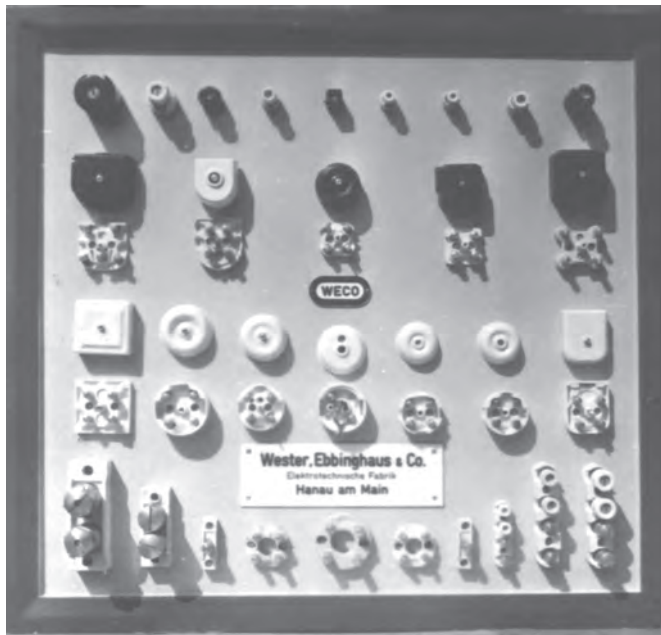

One of the first display panels with WECO junction box terminals

Over the years, enhanced materials and manufacturing processes improved the screw terminal. The original ceramic insulator was replaced by Bakelite in the 1920s, as it was more impact resistant, then further improvements were introduced with different plastics as these could be molded to resist higher temperatures, have improved flammability, be UV resistant, and meet the most demanding environmental conditions.

Progress in metal forming allowed new innovations, including connecting terminals in a screw or screwless technology. WECO's screw terminals have proven reliable and eventually migrated from Thomas Edison's original carbon filament lamp to Neon and fluorescent tubes and now to LEDs.

WECO currently sells over a million connectors to the lighting industry, all of which attest to the resilience and reliability of our brand. Our company is dedicated to Green Energy initiatives, as WECO provides connectors used in most LED lighting applications. Our connectors are found in advanced outdoor, roadway, infrastructure, and indoor LED lighting products WECO is committed to lighting a green future!

1930s

WECO is well known in the marketplace for specializing in the design and development of innovative electrical connectivity solutions. Our company provides engineering services and technical assistance, optimizes processes and products to improve existing technology, and offers flexibility in business, production, and service solutions to fulfill our customers' needs.

In the early thirties, WECO was known as „Wester, Ebbinghaus & Co Elektrotechnische Fabrik“, with a staff of 10 employees, operating at Alfred-Delp-Strasse in Hanau, Germany. By that time, it had already manufactured and distributed 2,000 different products, and was now focusing on developing new projects. WECO patented a new „terminal mantel“ connector, a design that proved successful and was accepted by the power industry and its engineers.

WECO continually improved its connector designs from the 1920`s and developed new products adapted to higher currents and voltages

that were suitable for larger power consumers. The new operating principle was a pressure pin that gripped the conductor in a slotted screw. The innovative feature of this new blanket terminal technology was the pressure pin secured by a screw in such a way that it could not come loose unintentionally. This was the original concept behind the „climbing cage“ still in use today! This design meant that, for the first time, the products were ideal for use in highly vibrating applications, a true revolution that significantly reduced the need for previous expensive maintenance.

With more than 2,000 products in its portfolio, the main components were the mantle clamps and the ceramic insulator. The clamp housings were made of drawn sheet metal, and the ceramic elements were used for insulation between conductors and as base/carrier insulators. WECO conducted several tests with different insulators and began using a „plastic“ material called Wecolit, a proprietary Bakelite product that had been developed earlier in the century.

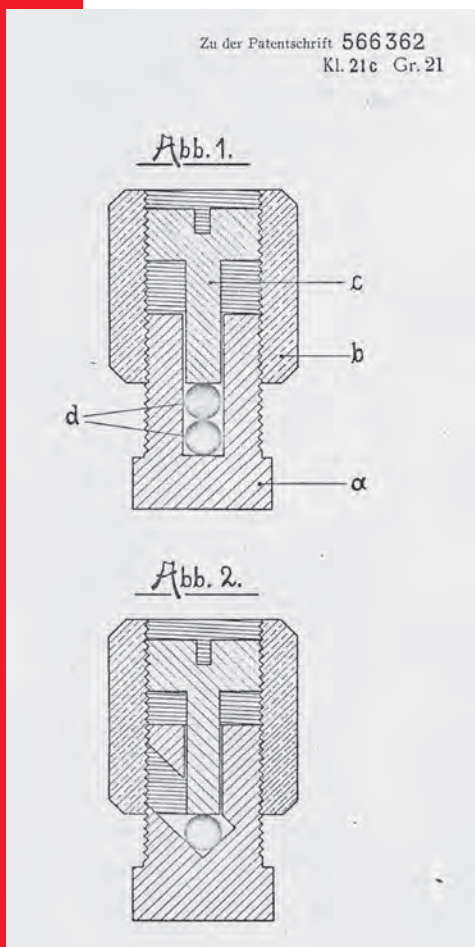

Drawing of a patent specification for „Screw slot terminal for electrical wires“ from 1932

These innovative products became the cornerstone of power connections. WECO's products improved over the years and are now incorporated into major power and energy industries. For example, manufacturers such as Bosch and EBZ use our products for power distribution and electronic meters.

Renewable energies or „Green Energy“ have long been a core element in the strategic orientation of our product portfolio. We offer a wide range of solutions whose main feature is sustainability in the products' manufacturing and durability.



WECO is present in almost all segments of the renewable energy market, from hydroelectric power to solar, wind, geothermal, tidal and biomass power plants. Our connectors are used in control panels in heat exchangers and heat pumps, as well as interconnections in EV chargers. Our goal is to continually lead this ever-growing renewable energy market with existing and new innovative products and solutions while expanding our market share.

1940s

The 1940s was probably one of the most important decades of the last century. The war and the technology that followed changed people's lives on a massive scale. In that decade, the primary inventions were the first successful mass-produced turboprop engines and the world's first fully automatic programmable digital computer - the „Z3“ computers. As part of a government project, Konrad Zuse built the Z3, the natural evolution of his original and rather limited Z1. The Z3 was also the first computer-controlled by software.

In the same decade, more precisely in 1943, WECO's production moved from Hanau to Bruchköbel. Looking back, this decision proved to be the right choice, as the original production facility in Hanau was destroyed in 1945. WECO immediately began its reconstruction; a newer, larger facility to accommodate its growing workforce, now counting some 90 employees and capable of meeting the rising market demand. This speaks for WECO's unwavering entrepreneurial spirit.

Our booth at the Hanover Fair 1951



In the mid 1940s, WECO managed to start a unique triumphal procession that resulted in a new patent; a new connector with insulating bodies made of thermoplastic material. This material allowed the company to offer new products that were unfeasible with the former insulating bodies made exclusively of porcelain or bakelite. This improvement to the original terminals used in the lighting industry was initially coined Lüsterklemmen or in French “lustre” meaning chandelier and was the precursor to the present-day Euro Style connectors. It made a big impact and was the „Top-Seller“ at the very first trade show.

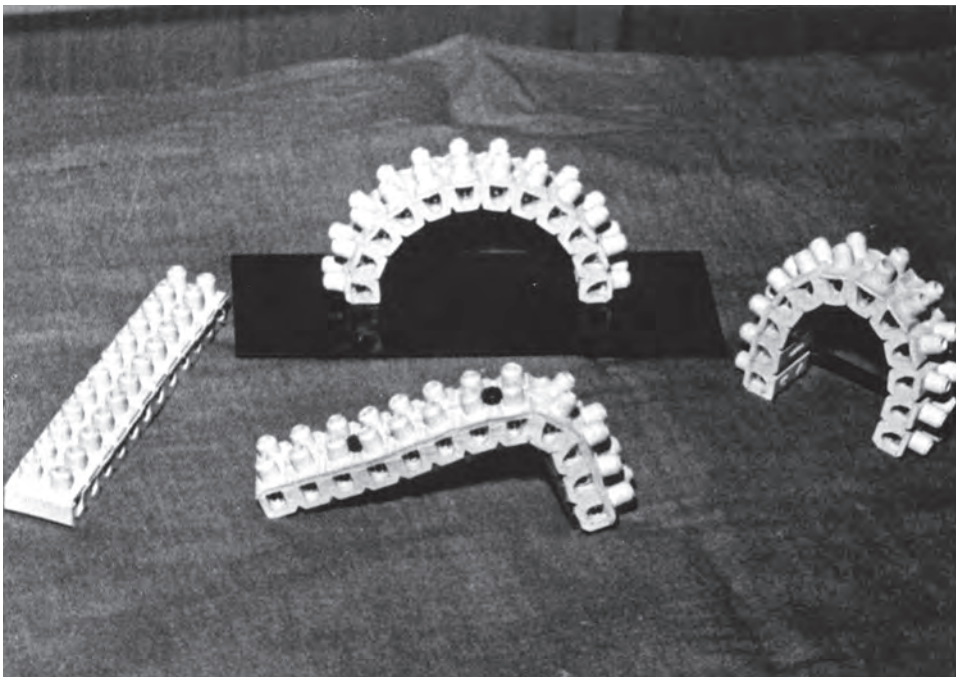

The big hit at the Hanover Fair: The „elastic terminal connector“

WECO entered the automotive market during the time when the automotive industry began to take over the market with the Volkswagen „VW Beetle“ - the first car for the general public, as it was affordable for the average consumer. With the new patented thermoplastics, WECO worked diligently on solutions for this new market, and designed a plug coupling used to connect electrical wires between the vehicle and the trailer. This was the prelude to the use of plug-in connections capable of withstanding harsh environmental conditions and strong vibrations. Other products for the transportation and automotive sectors followed. These products paved the way for WECO's entry into the new automotive and transportation markets!



WECO founder Eugen Ebbinghaus with his first VW Beetle from 1945

Although they have been enhanced over time, many of the connecting elements developed at that time are still in use today, and the success of these proven products has opened up new markets. Ceramic connectors with mantle terminals found their way into the shipping industry and are still used in the construction of new container ships due to their robustness and proven reliability.

WECO's introduction of PCB terminals has expanded to new areas of application in the automotive industry and in other segments of the transportation industry. Today, the focus is not only on robustness and resistance to vibrations, but also on fast and easy assembly and ease of maintenance. Our plug-in connections, which are sufficiently robust for use in dump trucks, are equally reliable and used in radio remote controls for crane systems.

WECO did not rest on its laurels, and patented SMarTconn, with its floating pin technology. These connectors opened new areas in the automotive market, and WECO made further inroads with applications in automatic transmission - a market segment that represents a decisive step into the future and which secures our brand.

1950s

The fifties were the beginning of the Baby Boom, a period full of optimism, when life was simple, jobs were plentiful, and a record number of babies were born. Countries experienced strong economic growth while consumer demand fueled the economy. The Baby Boom triggered a boom in housing, consumption, and workforce. The industry began to build and expand production facilities to meet this seemingly unquenchable demand with investments in new and modern machinery.



A view of the assembly department around 1946

As product demand increased, factories needed to adapt and automate their routine and repetitive operations. WECO was not immune to this same phenomenon. Early on, most production was labor-intensive, and all operations were manual.

In the early 1950s, new machines and equipment found their way onto the shop floor, although these were purely mechanical, WECO automated the cutting process on its new circular lathe. This simple „programming“ consisted of several asymmetrical metal control discs mounted one behind the other. The rotation of the discs-controlled tool arms, which then produced a finished metal part, thereby allowing WECO to increase its production.



Semi-automatic assembly machines for the 300 series in 1965

Regardless of the increase in the number of machines in the factories, there was still one worker per machine maintaining it and feeding raw material. As the amount of equipment increased, technology advanced and allowed more machines to work on a semi-independent basis. This initial level of mechanization opened a new market segment for WECO. The main products manufactured during this period were used for power supply to machines, power distribution, and assembly lines. The “Lüsterklemme” series introduced earlier continued to increase in popularity as new variations in plastics and pole sizes which solidified WECO’s position in the factory automation market. This series was later re-branded as the Series 300 or Euro Style connector.

The manufacturing segment has undergone huge changes since the beginning of the industrial revolution. Technological improvements have gone from simple mechanization to computer numerically controlled (CNC) processes and now to „cybernetic“ machines. Today, large machines can independently produce thousands of parts according to pre-made programs. All this could not be achieved unless electrical power was efficiently distributed to machines, with control panels that enabled communication. WECO’s products keep playing a major role in power distribution and interconnection of production equipment. Products designed and used in the 1950s are still in demand and in use today, attesting to the durability of WECO’s products.

In addition to the Euro Style Series 300, WECO developed several new connection solutions including the PCB terminal. Originally used on printed circuit boards for machine control systems, these connectors were initially intended for voltage distribution, but their reliability and easy use made them equally adaptable for signal connections.



The fourth industrial revolution (or Industry 4.0), gave birth to the Industrial Internet of Things (IIoT) - increasing connectivity and improving efficiency, all through data. The need for innovative connection solutions has blossomed as control panels have shrunk in size, resulting in greater power distribution over a smaller, densely populated PCB. As more sensors are used to monitor plant equipment, more signals need to be processed from a single power control board; the requirement for space-saving solutions becomes even more essential.

WECO plays a role with its reliable SMD products and patented SMarTconn connectors where the products can be soldered to both sides of the PCB. WECO has proven over the decades that its products are user-friendly and adaptable to the requirements of modern factory automation. Our vision is to become the first choice in tailored electrical connection solutions for industrial applications worldwide.

WECO is a global company headquartered in Montreal

Over the years, with technological revolutions and expanding markets, WECO has taken expansion by building on talented teams, trusted partnerships, and establishing strategically located factories in Germany, Tunisia, and Canada. Our presence in Asia-Pacific, Europe, Latin America, North Africa, and North America allows us to reach customers globally and provide efficient customer service.



Meet our Commercial Team



Marc Villeneuve
Director Sales & Marketing
North America



Detlef Fritsch
General Manager
EMEIA



Amelie Pan
General Manager
Asia Pacific



Yuritz Cisneros-Peguero
General Manager
Latin America



Ana Flavia Ronzani Rodrigues
General Manager
Brazil

Contact us at info@wecoconnectors.com



 Countries WECO has Production Facilities and Commercial Office

 Countries WECO has Commercial Offices

China
Hong Kong

Our Key Performance Indicators

Proud of our operational excellence and solid performance, we have KPIs representing what we believe the most. WECO is always looking for continuous improvement and could be considered an innovation seeker.



Zero-Failure-Principle

Plug & Play



Quality

High Quality products



Compliance

with international standards



Response

Quick replies, answers, solutions, quotes, ...



Agility

Agility in production



Delivery

On Time Delivery



TCO

Live Total Cost of Ownership

1960s

After the huge baby boom in the previous decade, technical developments in communications turned TVs and phones into basic home items. Their use expanded on an exponential basis, while the industry started using the first digital transmission media, such as fax machines and electronic typewriters.

Switchboard operators physically transferred the call from one line to another using a series of plug-in cables. A power distribution mechanism became necessary to allow the large switchboards to operate. WECO provided an early variation for the screw barrier strip. Originally made of Bakelite, the screw terminals took off as each of these new media was using a basic component called printed circuit board that enabled the distribution of signals and electrical power.



WECO junction box terminal of the 2002 series (around 1950)

Communication became another new market for WECO, resulting in the development of new products designed with PCB terminals. During this period, WECO's product line expanded to 15 new connector families, including the development of a new „flat“ series, later called MINIFFLEX KUPPLUNG or coupling.

With a new market to serve and through the expansion of its product line, WECO increased its workforce by more than 150 employees. The communications market not only expanded WECO's product line, but also allowed the company to set up its in-house tool shop, for the purpose of supporting the need to manufacture production dies and connectors.

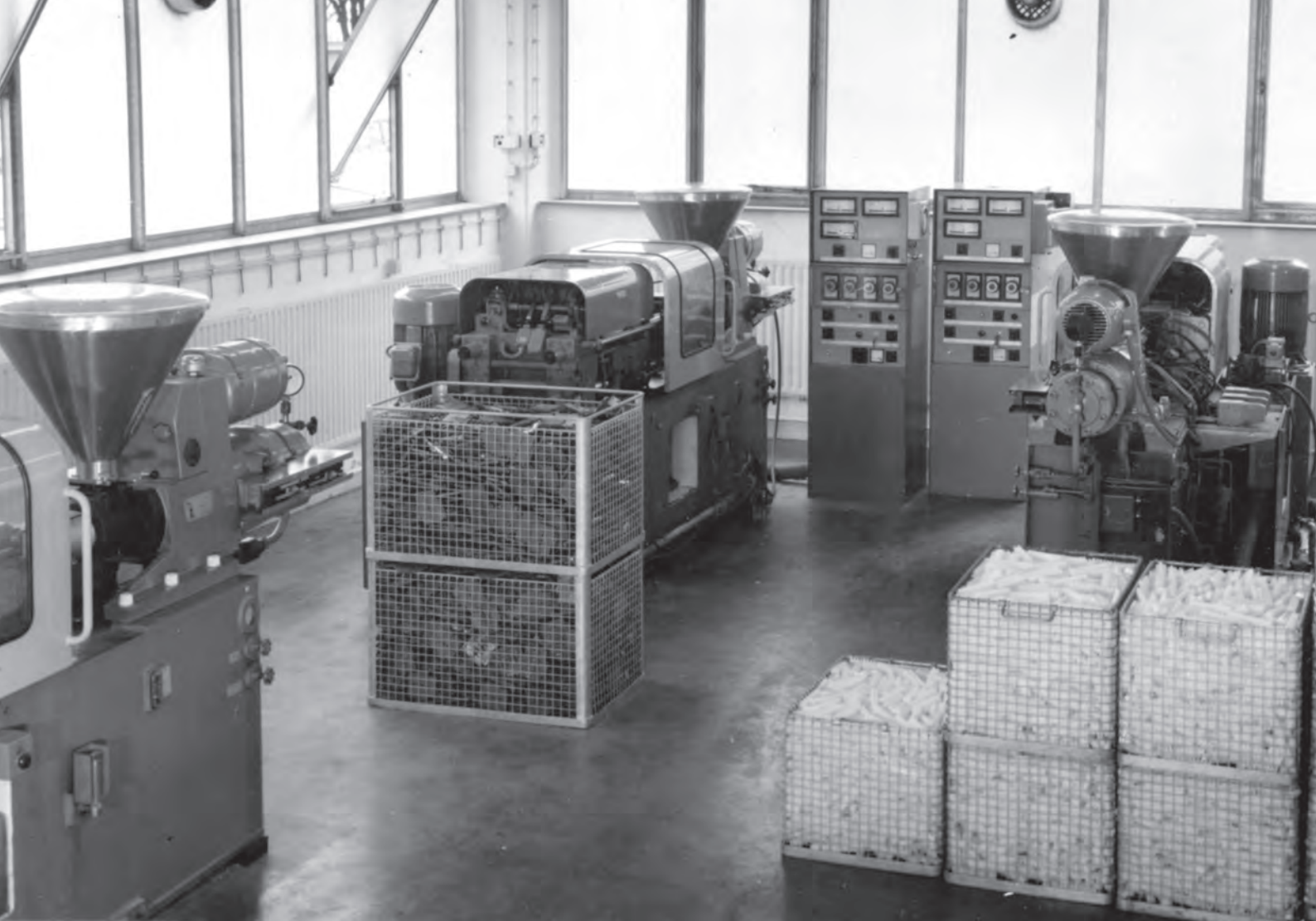

A look inside the WECO plastics injection moulding department around 1970 with the first injection moulding machines

In 1965, WECO invested in its facility; it initially expanded its current plant and acquired the adjoining property in downtown Hanau, and then purchased a plastic injection molding machine, followed by the other four. These were major leaps toward expanding the product range with new molded plastic housings and the ability to quickly react to customers' demands, a first step in WECO's agility. From then on, all PCB terminals could be manufactured internally, allowing WECO to meet the growing market demand and turning the company into a stronger partner for customers in the electronics industry.

Dr. Walter Ebbinghaus, the founder's grandson, managed the company during this period and played a major role in expanding WECO's success for the next 29 years. The fast economic development was also felt in the payroll sector. The wage increase not only benefited employees, but also became the foundation for a consumption-driven, affluent society, which in turn benefited companies such as WECO.

To give you an idea of local wages at WECO at those times, check the wages table and get to know how it compares to your current wages:

YEAR	WAGE	CATEGORY
1948	DM 1,10/h	for skilled workers
1954	DM 0,75/h	for unskilled workers
1969	DM 3,86/h	for skilled workers

The technology of WECO's products eventually migrated to new communication platforms, from POTS (Plain Old Telephone Systems) to today's cellphones, in which our connectors are used to power cell tower transmitters and power transmission equipment. The need for connectivity innovations flourished with new solutions that could save space to maximize PCB real estate. Surface mount technology (SMT) is not only required to save space for low current signal connectors, but also for power terminal blocks to deliver power at a higher current. Today, WECO has an extended line of SMarTconn connectors to serve this market.



1970s

The 1970s can be coined as the „decade of expansion“ and a significant step for WECO. Despite some plant expansions, the old factory in downtown Hanau was no longer adequate to house production and the increasing staff of 250 employees.

WECO acquired a new site on the outskirts of Hanau in 1971 and began planning for a larger factory and headquarters. Construction works began in 1974, and after some drawbacks mainly due to the oil crisis, WECO finally moved into its new building at Donaustrasse 15 in 1976, where the factory is still located.



The new plant site in the Hanau industrial area in Germany shortly after completion

During the seventies, production increased to meet the needs of WECO's customers, and while this was seen as positive, price pressures caused by wages and salaries nearly five times higher compared to the last 25 years required WECO to reinvent itself.

WECO's General Manager at that time Dr. Walter Ebbinghaus and the shareholders developed a new strategy and sought a second production site. This time Tunisia was the choice given its competitive cost, proximity, and highly skilled labor force.

With its new location and increased production capacity, WECO entered a new market segment consisting of heating, ventilation and air conditioning, or „HVAC“ systems. To succeed in this market, WECO designed new products to meet the harsh environmental conditions, including wide fluctuations in temperature and humidity. To this end, WECO used special plastic compounds for the housings and selected engineered surface coatings for the metal components. This new market contributed to WECO's development of several new connection solutions over the years using its past knowledge and experience, resulting in the development of a new plug-in connector concept developed with its unique geometry and locking parts to resist vibrations. This was the basis for today's extensive range of PCB terminal blocks.

WECO's product range was further enhanced during this period with its portfolio of „flat“ or tab connectors mounted on a terminal strip. This new connector design increased flexibility in production for our customers by allowing modular assembly where multiple modules could be easily and quickly „plugged in“. These tab connections were the first generation of our current 307 series, as they proved to be reliable in withstanding vibration and harsh conditions, thus becoming the standard in the HVAC industry and still widely accepted.











Flachsteck-Verbindungsleiste mit Flachstecker 6,3

Pl. Nr. 307 und 307 K
 Flachstecker-Anschlußmaße 6,3×0,8 (Serie 250)
 für Stechhülsen der Nenngröße 6,3
 DIN 46247 Bl. 3



Unsere Standardbestückung der Pole mit Geräte-Flachsteckern der Seite 4/24.

 4	 5	 6
 25	 20	 24
 27	 31	 32

Der Schraubanschluß ist auch mit dem Geräte-Flachstecker Pl. Nr. GST SAK-O lieferbar (Seite 4/24)
 Bestell- oder Anfragebeispiel mit Skizze einer 10-poligen Flachsteck-Verbindungsleiste.



Bei Anfrage bzw. Bestellungen bitten wir um **Ein-sendung einer Skizze** gem. vorstehendem Beispiel. Aus dieser muß die gewünschte Polzahl, die Bestückung jedes Poles sowie die Nietart (normal, ohne Zusatzbezeichnung; Metallnietung, Zusatzbezeichnung „M“ zu ersehen) und der Werkstoff des Sockels bezeichnet sein.

Nennspannung nach VDE 0110
 Isol.-Gr. C / 380 V
 Mit einer zusätzlichen Isolierplatte als Auflagefläche (bei einer vorhandenen metallischen Gehäusewand) erhöht sich die Spannung auf Isol.-Gr. C / 500 V

Nennquerschnitt 4 mm²

Strombelastbarkeit 25 A nach REC 2

Beschreibung der Verbindungsleiste siehe Seite 4/20.

Werkstoff:
 Der **Sockel** aus Formpreßstoff ist lieferbar in:
 Typ 31 Pl. Nr. 307
 Typ 150 Pl. Nr. 307 K
 Formbeständigkeit mind. 120 °C
 Kriechstromfestigkeit nach VDE 0303
 Typ 31 KA 1
 Typ 150 KA 3b

Metallteile:
 Flachstecker Messing verzinkt
 Rohrniet Kupfer verzinkt
 Klemmschraube M 4×6 5 S verzinkt

Preise: Wegen der Vielfalt der möglichen Ausführungen ist die Angabe von Preisen in Listenform nicht möglich. Wir unterbreiten gern spezifiziertes Angebot auf Anfrage.

4 / 21

The product line evolved to allow multiple connections on one pole, so customers could customize the connection between each pole and multiple outputs, an innovation for WECO's product. Other connection solutions with tab connectors were implemented thanks to in-house molding of plastic housings that gave rise to our 420 and 406/407/408 series, a PVC terminal strip with tabs.



The advantage of plug-in terminal strips with tabs has proven to be efficient when it comes to maintenance. Here, maintenance times are reduced as connections can be quickly and safely disconnected and then safely reconnected once the maintenance is complete. With an industry standard for tab dimensions, the risk of a contact becoming loose due to vibrations is reduced to nearly zero, and since then the HVAC industry relied on WECO as an ideal and reliable partner for existing products and new developments.

1980s

For WECO, the 1980s were boom years. Despite a recession at the beginning of the decade, the global economy outperformed in 1988 and grew at a new pace. The plans for a new factory in Tunisia, initiated in 1978 by our Managing Director, Dr. Walter Ebbinghaus, became a reality. "Conecta Tunisie" came on stream in 1981, employing nearly 300 operators. While the main plant in Germany manufactured components such as housings, terminal bodies, and stamped parts, the Tunisia unit was designed for the final assembly of our products.



The company site in Tunisia 1981

The dedication and resilience of WECO's employees became evident during a major flood at the Tunisia facility in 1983. Production came to a standstill, yet all employees stood by WECO and began cleaning and clearing debris, water, and mud and within 3 weeks the plant resumed production!



WECO Electrical Connectors in Baie d'Urfé 2008

After establishing the plant in Tunisia, it was time to conquer the American market. In 1983, WECO founded another company in the heart of Canada, in Kirkland, Quebec, named „WECO Electrical Connectors“. In addition to a production facility, the company set up its own product development department to support the U.S. and Canadian markets.

The expansion also began in Europe, with the founding of the first subsidiary in Switzerland in 1986, which was named „Conecta Fleurier“. Here, the first fully automated assembly line produced our 300 series products.

To continue WECO's expansion plans, top ranked manufacturers representations were added and with the addition of 20 well-know agencies around the globe and with its 4 branches in Germany, Canada, Tunisia and Switzerland, WECO was now a global player for Terminal Blocks!

With its global reach and new facilities, WECO forged a new market: „White-Goods“ or appliances, such as refrigerators, ovens, and microwaves, when it comes to power connection components. Our main products at that time were our 300 series, 307 series, and ceramic connectors. With the introduction of new appliances, WECO developed new products and added new PCB terminals, thereby facilitating the assembly and maintenance of the appliances.



Ceramics played an important role in power distribution in large commercial and industrial furnaces. Proven reliability over the years makes WECO's ceramic terminal block the key choice among design engineers.

Over the decade, WECO continued to develop new variations of its 300 series terminal blocks and PCB connectors. With approximately 60 active product variants in different pitches, screw connector strips, plug-in connectors, raised versions, and

angled connectors, WECO's portfolio of these series is perfectly suited for any device application, whether used in commercial, industrial or residential applications.

For WECO, the appliance market is not only targeted at residential applications; our connectors are also present in commercial ovens, as previously mentioned, and in commercial refrigerators found in our grocery stores. From the former open freezers to modern glass door refrigerators lining the aisles of our supermarkets, WECO's products can be found and are used to distribute power using our tabbed and PCB connectors to connect the temperature control boards. Our products contributed to improving refrigerators' energy efficiency and the customers' shopping experience. Customers no longer had to dawn a jacket while walking down the aisles in the frozen food section.

1990s

While the last decade has seen years of expansion, WECO has now turned its focus to the development of terminal blocks and solutions for a new market focused on environmentally friendly products.



Political unrest in the OPEC countries dramatically exposed the world's high dependence on oil, and the industry reacted with alternative solutions for heating water and homes. Tankless water heaters emerged, as did high-efficiency heat pumps. These heaters provided an efficient way to heat water on demand and heat pumps provided a cost-effective way to extract heat from the outside temperature to heat homes.

WECO's resilience withstood the global economic crisis of 1992 and, although faced with job cuts, it soon recovered, as did its workforce and its product range, which grew to 20,000 products, almost doubling in 30 years.

On April 1, 1993, WECO reached another milestone in obtaining DIN ISO 9001 certification, enabling WECO to supply larger international companies that

required this certification as a prerequisite for being approved as a main supplier. From WECO's viewpoint, all processes and procedures were now traceable and documented in a reproducible way.

A step toward even higher quality standards. Since then, this certification has become standard throughout the WECO group. This new certification again provided an upswing and an increased demand for WECO's quality products. As a result, WECO's workforce grew to nearly 400 employees internationally by the mid-1990s.



The fire at Düsseldorf Airport, Germany in 1996

In 1996, a devastating fire with 17 deaths at Germany's Düsseldorf airport changed the way plastics and insulating materials were handled and used on the world market. The realization that older plastics containing halogen can release toxic substances when ignited poses an extreme risk to people's health opened a discussion on the topic of plastics' fire behavior, resulting in a new standard labeled „No Flame“ material with stricter fire safety regulations.

WECO immediately put its housing materials to the test and produced the first series with flame retardant and self-extinguishing plastics to meet these new

regulations. What emerged at that time from a catastrophe is now an internal standard and a significant new market for WECO, Fire Protection & Safety.

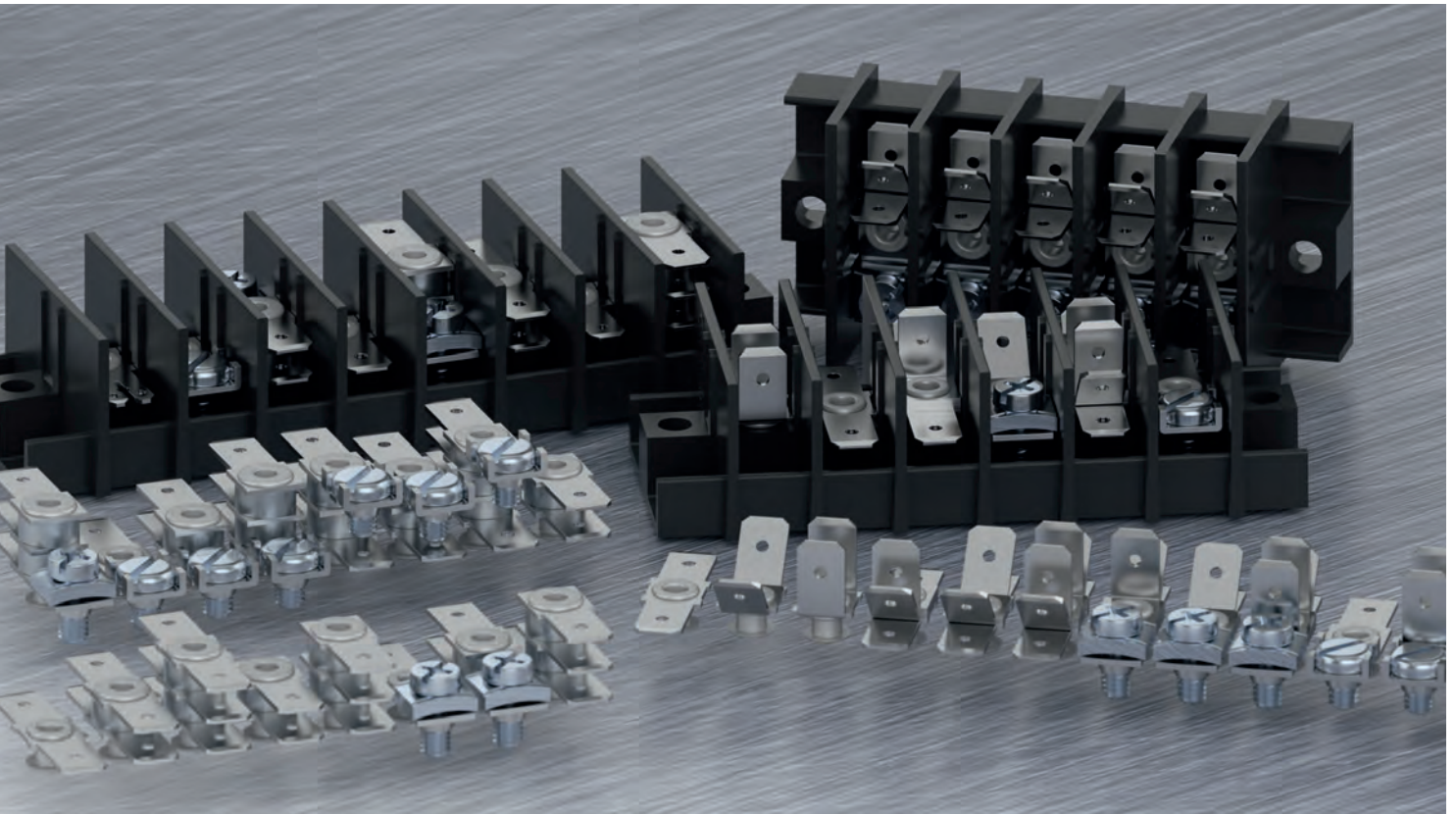

Our WECO tab connector strips of the series 307/3070

These new plastics found their way into many of WECO's products; our 300 series terminal strips, 307 and 308 series flat plugs also in our PCB terminals, and our SMarTconn series. While terminal strips and flat/tab connectors are primarily used for power supply in tankless water heaters, SMD and THR terminal blocks are found on the circuit boards used for central control and regulation of these devices, as well as used in fire and security products.

In parallel with WECO's product expansions, WECO continued to enter new global markets and established another subsidiary in Brazil. Finally in 1999, „WECO do Brasil LTDA“ was founded, with headquarters in São Paulo. With the sales office there, and a small staff of only 2 people, WECO was able to serve the local market quickly, and today, WECO do Brasil is an important part of the WECO Group.

2000s



WECO do Brasil in Curitiba 2007

America and in 2007 moved its office from São Paulo to a larger building in Curitiba, capital of the state of Paraná, Brazil. In addition to the sales offices, there was also a warehouse and, for the first time, the company's own assembly facilities. The move to Curitiba placed WECO closer to the industrial center of this region and more capable of meeting the demands of the Latin American markets.

WECO entered the new century by expanding its reach in Asia, opening its first sales office in Hong Kong in 2006 and a second office in Shenzhen the following year. This new decade initiated the beginning of WECO's global reach. WECO now had more international reach with its direct access to the Asian market.

Once established in Asia, WECO concentrated on the emerging markets of South



WECO de México in Tlajomulco de Zuñiga

WECO continued its expansion in the South American market adding a sales office in Tlajomulco de Zuñiga, Mexico in 2009. Since then, WECO has expanded its presence in Mexico with a warehouse and today with its 5 employees provides services not only in Mexico, but also in Central America.



Over the decade WECO expanded its range by developing new products and in 2005 launched the New Product Guide with around 31 new products focusing mainly on SMD and THR products, including its first Tape-&-Reel products to serve high-production assembly lines. WECO patented SMarTconn products in 2009 and released the first SMarTconn catalog.

The rapid advancement in cities' infrastructures and the desire for more compact monitoring devices made it necessary to save space on the circuit boards. This is where WECO's SMD products began their triumphal progression. As a product specifically designed for surface mount, WECO's SMarTconn connectors allowed the PCB layout to be completely redesigned and eliminating the processing steps to solder through-hole pins. Printed circuit boards real-estate could be maximized and used on both sides.

Modern pick & place machines for automatic loading require trays or tape products. In 2005, WECO included its successful 971-SLK pinhead in its product portfolio as the first Tape-&-Reel product. Today, WECO's portfolio includes around 40 series of SMD and THR products in Tape-&-Reel.



WECO continued to discover and penetrate new markets by promoting its proven and reliable products and established its entry into the Public Infrastructure Market. The lighting of buildings and public places in urban areas has become increasingly popular as an architectural element. When the first LED lighting systems were used in street and building lighting in the mid-

2000s, this brought completely new applications and the introduction of accent lighting creating an inviting atmosphere for people to gather in city center squares. Floodlights, outdoor luminaires, downlights and uplights, as well as spotlights required more complex controls and for the power supply, as well as for the electronics that controlled the LEDs. WECO's products are ideal for both power distribution and on-board signal wire connections.

Proven reliability to withstand vibrations has made the WECO product a natural choice in escalator and elevator controls. Worldwide, WECO products are an integral part of the cabling systems of major players in the infrastructure mobility segment.

WECO global expansions with independent offices did not come without pain. In 2009, WECO fell on hard times and our company, known as WECO Wester, Ebbinghaus GmbH & Co. KG was now insolvent and had no choice but to reinvent itself. The new company WECO Contact GmbH was established in 2010 and the WECO brand survived with confidence in its product and loyal customers and employees.

2010s

From its modest beginnings, WECO strove and prospered and, in some cases, faced challenges. To recover from financial losses, WECO needed to reinvent itself. It is a company based on the pride and respect of its employees, and in no way was WECO about to give up. To meet global competitiveness, WECO needed not only to regain profitability but to turn into a global entity, becoming „ONE“ WECO.

Under the leadership of its new CEO, Mr. Heiner Kammann, WECO began to globalize and unify its subsidiaries. It increased its competitiveness, centralized business intelligence, unified its independent subsidiaries, and collaborated with its regional offices. It became ONE WECO, a sales and engineering company.



The company headquarters in Montreal, Canada

WECO took advantage of economies of scale for raw material procurement and conducted an expansion project in the Czech Republic, where our high-volume 302 to 327 series were manufactured until closing down in 2017. Mr. Kammann established a global headquarters in Canada, first with a factory on the western tip of Montreal Island in Baie-D'Urfé, and then moved to Kirkland in 2012, which became the new global headquarter in 2015.

Mr. Kammann returned WECO to profitability by eliminating redundancies and aligning it with its established markets and customers. From this point, Bernard Pinet took over in 2010 and expanded on Mr. Kammann's vision, creating a solid and engaged executive team and turning WECO into a customer-centric organization until his retirement in 2020. Now, Mr. Michel Alary takes over the role and continues to move forward with our new vision and mission. Collaboration in all facets of the company is now evident and we are now a truly global organization.



The new production plant in Tunisia since 2020

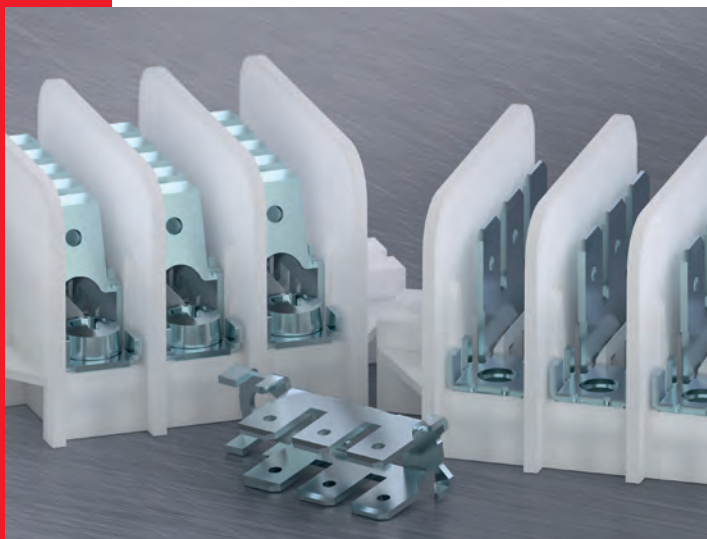

The tab distribution blocks of the 308 series

Improvements in manufacturing resulted in consolidating the factories in three facilities: Hanau, Canada and Tunisia, which relocated to a new and larger premise ready for future growth.

WECO not only created a customer-oriented organization, but also expanded its product range by acquiring the tooling and production machinery from the German company Metalluk in 2017 to produce a multi-tab connector and integrated the products into its own portfolio, branding it as our Series 308. This line of multi-tab connectors allowed WECO to increase its penetration into the automotive/transportation market as the product is geared to motorhomes for power distribution. This market has grown significantly in the past few years as more consumers are reverting to an easier life with camping in their new motorhomes – a positive effect from the current pandemic situation.

Further advances were made in the automotive market with WECO developing a tailored solution using a pin header based on our patented floating pin technology, which is used as a connection between the transmission and control box in new SUV models. It took nearly 2 years of intensive engineering work with the first samples leaving Hanau in 2019 and this year a fully automated production process was brought online to support the customers' needs.

Security in public and private places became a normal way of life. Monitoring the flow of people through metro and public transportation networks has generated BIG DATA that helps cities efficiently manage their infrastructure safely and securely. Interconnecting a myriad of devices requires reliable and easy-to-install connectors in the field; here the WECO 950-NLFL and 971-SLR-SMD series are in high demand, specifically in devices such as smoke detectors, emergency lighting, and alarm control centers.



WECO's competitive edges found their way into many new and modern building projects worldwide, such as, for example, the Vodafone office in Portugal, which integrates Fire and Security Systems that include WECO connectors.

100 Jahre mit Herzblut dabei

Die Zwillingbrüder Stein feiern je 50 Jahre Betriebsjubiläum bei der Firma Weco

Von Rainer Habermann

HANAU • 50-jähriges Betriebsjubiläum? Wie geht das denn, in der heutigen Zeit? Nicht für eine Firma, sondern für einen Betriebsangehörigen, einen Arbeiter, wohlgeehrt. Gleich doppelt konnten am Dienstag die Zwillingbrüder Wolfgang und Werner Stein ein solches „Fuffziger“ feiern, und verkörpern somit quasi 100 Jahre Firmenerfahrung der Weco Contact GmbH im Hanauer Gewerbegebiet Nord. Am Dienstagmittag ist das doppelte Jubiläum gebührend gefeiert worden.

Es ist tatsächlich eine Geschichte, die ein wenig ans Herz geht. Am 18. September 1968 haben Wolfgang und Werner Stein bei der Weco angefangen. Wolfgang ist übrigens der ältere der beiden Brüder; er kam ziemlich exakt zehn Minuten früher zur Welt.

Sie arbeiteten zunächst in der Spritzerei und der Montageabteilung, für einen Stundenlohn von 1,17 D-Mark pro Stunde. In heutigen Ohren mag es lachhaft klingen, aber die Löhne waren in den 60ern so niedrig. Ungerechnet für knapp 60 Euro-Cent pro Stunde hieß es anpacken, und zwar kräftig. 14 Jahre alt waren die Zwillinge damals, die Lohnrüte (ja, auch die gab es damals und wurde wöchentlich mit Bargeld aufgefüllt) reichte aber, um die komplette Familie zu ernähren. Denn als der Vater starb, zählten die beiden Jungs gerade mal 15 Lenze. Die Mutter lebt noch heute, ist 87 Jahre alt und richtig stolz auf ihre Söhne, die es so lange in ein und derselben Firma ausgehalten haben. Nicht nur ausgehalten: „Unser Herzblut gehört der Weco“, sagen beide wie aus einem Mund.

Der Geschäftsführer der Weco, Diplomingenieur Deref Fritsch, hörte es gerne: Er war der Laudator bei der Jubiläumsfeier im Innenhof des Firmenkomples an der Donaustraße. „Selbst wenn wir in unserer seit 97 Jahren bestehenden Firma viele Mitarbeiter haben, die schon sehr lange bei uns sind, so ist die Geschichte der Zwillingbrüder Stein schon eine außergewöhnliche. Und dafür wollen wir sie heute ehren, für ihr jeweils 50-jähriges Betriebsjubiläum“, erklärte Fritsch unter dem Applaus der versammelten Belegschaft.

„Bescheidenheit, Ehrlichkeit, und ein liebevoller Umgang miteinander wie auch mit den Kolleginnen und Kollegen: das war und ist bis heute für die beiden Herren Stein charakteristisch. Die beiden sind wirklich wie Pech und Schwefel“, lobte der Chef.

Da ist aber noch die Schwester der Zwillinge, Marion Schuck. Drei Jahre ist sie jünger, und sie habe „Feuer ins Leben der Brüder gebracht“, so Fritsch. Auch sie arbeitet bei der Firma Weco, und – man glaubt es fast nicht, wenn man sie anschaut – feiert im kommenden Jahr ihr 30. Firmenjubiläum. Marion lässt ebenfalls nichts auf ihre beiden Brüder kommen. „Sie leben für die Firma“, sagt sie. „Wolfgang hat sogar noch zusätzlich Heimarbeit gemacht, damals.

Und wenn sie im kommenden Jahr in Rente gehen, dann wird irgendwas hier fehlen.“

„Das ist so, wie wenn Eltern in Rente gehen“, sagt eine andere Dame am Feiertisch unter den Pavillons im Innenhof. Sie arbeitet in der gleichen Abteilung wie die Zwillinge heute: in der Montage. „Ich kann mir das noch gar nicht vorstellen. Die Zwei sind immer gut drauf, ich glaube, wir werden sie alle sehr vermissen“, verdrückt sie ein kleines Tränchen.

Wenn man den Erfolg der Firma Weco über so viele Jahre sieht – auch die Dame gehört bald 30 Jahre „zum Inventar“, dann gewinnt man etwas Abstand zur „Hire and Fire“-Mentalität, so manch anderen Unternehmens. Offensichtlich erzielt man Erfolg auch mit Vertrauen und Kontinuität, selbst in stürmischen Zeiten. Und wenn man es genau nimmt, dann gehören die Steins mit insgesamt 130 Jahren Erfahrung im Job ganz sicher zu einem gewaltigen Betriebskapital.



Wolfgang (links) und Werner Stein halten der Firma Weco seit 50 Jahren die Treue. Mit 14 Jahren begannen die Zwillinge dort zu arbeiten. • Foto: Habermann

With a hundred years of existence, WECO is built on the dedication and responsiveness of its teams of employees, each of whom contributes to the family on a daily basis. Proof of this dedication, and one that has made WECO proud, is the longevity of its employees. Even if it would still take another three years until WECO's true centennial, a centennial could have already been celebrated in September of 2018. Two brothers, who punched their first timecard in September 1968, celebrated their 50 years of service to the company that year. WECO honored the two jubilarians with a celebration.

We, the employees, are the „WE“ in WECO. WE all contribute to the success and WE are the pulse of the company.

For that, everyone at WECO appreciates your dedication and your work. It is with great pride that WECO thanks you for being part of this journey, a journey that will continue into the next century.



Long lifetime - this does not only apply to connection products from WECO

WECO's pride and longevity is undeniable in its products and the people who design and assemble them. This was evident when a poster advertising our products at our first exhibition in Hannover in 1954 appeared on eBay 63 years later in near perfect condition! It was sold in 2017, but unfortunately, WECO was not aware of it and it was too late to buy it. Its new owner is certainly displaying it with pride.

Just like the poster, WECO prides itself on having the best employees building the best products and gearing up for the next century.

Celebration around the world



June 21, 2021



WECO

Your partner for the future.





CREDITS

PROJECT TEAM „100 YEARS OF WECO“

Marcus Busch, Yuritzzi Cisneros-Peguero, Detlef Fritsch,
Adriana Galli, Ana Flávia Rodrigues, Marc Villeneuve

IDEA AND LAYOUT

OUI Marketing Agency, Brazil

TEXT

Marcus Busch, Detlef Fritsch, Marc Villeneuve

IMAGES

WECO Archive, WECO Celebration Parties,
Blender and various stock portals

REVISION & PRINT VERSION

Marcus Busch

SUPPORT

By all WECO employees worldwide

PRINT

DATA Print GmbH, Germany

© WECO, August 2021



www.wecoconnectors.com

