

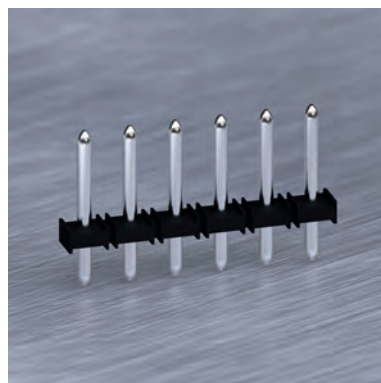



# ■ Connection Technology on Printed Circuit Boards SMD & THR

6

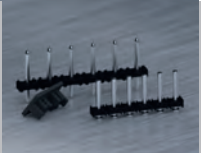

# Content

Overview	<b>4</b>	
The WECO Group	<b>5</b>	
Household Appliance Standard	<b>6</b>	
RoHS	<b>7</b>	
Symbols on our data sheets	<b>8</b>	
Products for lighting applications	<b>9-18</b>	
PCB connectors SMD THR	<b>19-32</b> 20-26 27-32	
Pin strips SMD THR	<b>33-44</b> 34-38 39-44	
Pin strips as system connectors SMD THR	<b>45-57</b> 46-51 52-57	
Coding systems	<b>58</b>	
Marking	<b>59</b>	
Packaging	<b>60</b>	
Moulding colours / Screws	<b>61</b>	
Soldering processes	<b>62</b>	
Technical Information	<b>63-65</b>	
Index	<b>66</b>	

## Overview

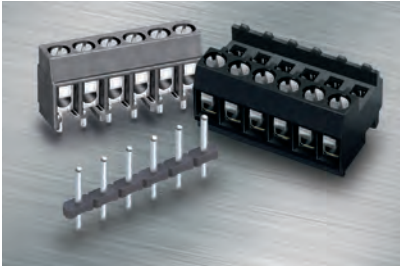

### Connectors for printed circuit boards

WECO PCB connectors always offer a good solution for almost any connection problem by its big variety of types. The screw connections are available in socket terminal style, in elevator clamping style or as head contact terminals. The plug connectors are especially designed for the connection of components or peripheral devices. Tab connectors and screwless types complete the product program.

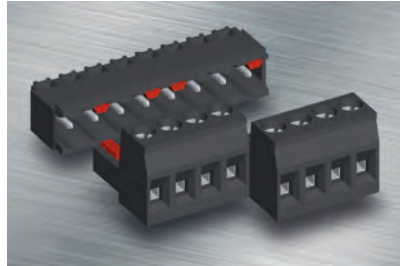

### Plug-In connector systems

The plug-in connector system consisting of plug connectors with screw and their corresponding pin strips. Due to four different pitch sizes, lateral flange executions, tier versions and different plug directions, this product series suit almost every application on the PCB. All connectors offer coding possibilities to avoid incorrect plugging.

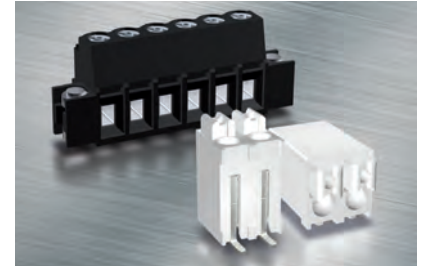

### SMD & THR

“SMarTconn” covers terminals and plug connectors for surface mount and reflow soldering technique. Apart from the proven Through-Hole-Technology (THR) we focus on genuine SMD - Surface Mount Devices – in this product serie. With their reliable adhesive forces and their good reflow soldering capabilities, we offer products, which are a worthy replacement for the conventional soldering technique. All products of this series are packed in tape-on-reel or tube magazines for the automatic assembling with a pick & place machine.



### Terminal strips

This group contains socket terminals, plug-in connectors, screwless types and additionally the combination of screw and solder tag for the wire-to-wire connection. All types are available for different cross sections, with and without wire protectors. The used Polyamide plastic material pass the ball pressure test with 125°C according to VDE 0470, which is demanded in many IEC and VDE regulations for insulants.



### Tab connectors

These connectors are equipped with receptacles in different sizes and styles. Mixed arrangements per terminal block as well as per pole (Multi-Point Tab Connectors) are possible. Combinations of tab / solder connectors, flat plug couplers and space saving tier versions increase the density of connections. The tab connectors offer a wide spectrum of possible combinations, whereby many connection problems can be solved.



### Ceramic terminal blocks

This group covers mantle terminals, ceramic terminal strips and terminals for explosion and firedamp-hazard areas. Various sizes and designs permit them to be used for wire cross sections up to 120 mm<sup>2</sup> and including applications in furnace construction and ship building, for engines and intrinsically safe electrical equipment. The terminal blocks with ceramic insulator can be used at increased temperatures.

## The WECO Group

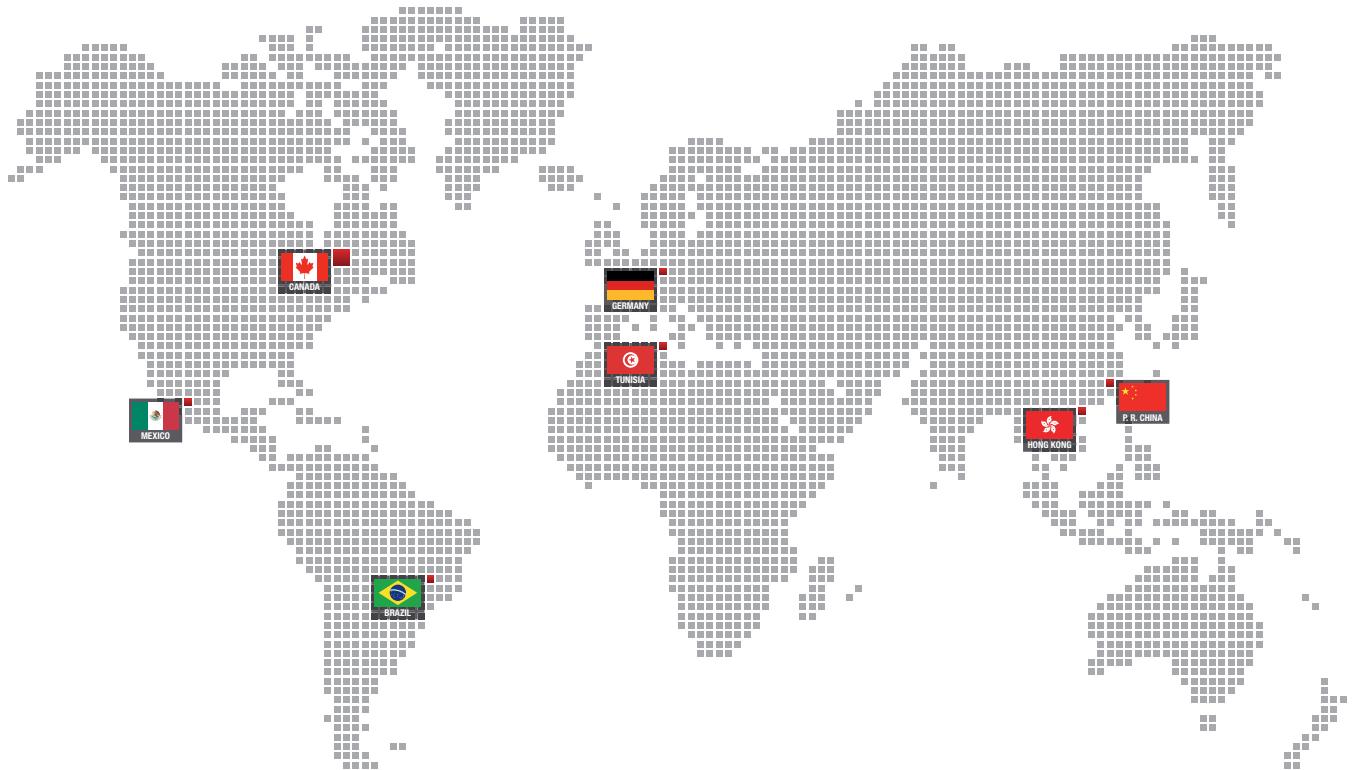

**For more than 90 years, WECO has been one of the leading recognized partners for safe and top-quality connectors in the field of electronics and electrical engineering.**

With our globally operating sales network, own production plants, competent and experienced contact partners, we are always at your disposition on-site. From our extensive portfolio of 17,000 different articles but also with customized products, our team of about 450 employees will find you the optimum solution for your specific requirements. Our designs are always based on the latest standards from UL, CSA and VDE.

Our unique custom designed specific developments prove the high level of innovation power of WECO products and services. The fast and flexible project implementation in combination with delivery reliability ultimately enables us to flexibly respond to the increasingly challenging demands of the market.

Our patented product series for Surface Mount Technology (SMD), suitable even for rough surfaces, provide you with significant cost savings in production and quality control processes.

Customer satisfaction and the durability of our products are our top priorities.

You can always count on WECO as your competent, cooperative and reliable partner for secure connections - worldwide.

# Household Appliance Standard DIN EN/IEC 60335-1

## What is the household appliance standard all about?

The household appliance standard DIN EN/IEC 60335-1:2012-10 standardizes the safety features of electrical appliances for household and commercial use whose rated voltages do not exceed 250 V for single-phase appliances and 480 V for other appliances.

## Which aspects of the household appliance standard are particularly important for WECO products?

**Chapter 30: Heat- and flame-resistance.** Components made of non-metallic materials holding active components (e.g. connection elements) in position must be resistant against ignition and fire propagation. Electrical appliances are divided into several classes. Depending on their application, they are tested according to different methods.

Most WECO products meet the requirements for unattended appliances with currents > 0.2 A. These requirements stipulate the glow-wire resistance test for non-metallic materials and refer to other glow-wire tests.

These flame-resistance requirements shall prevent self-ignition of unattended appliances. On the market, they are designated as “no flame”.

## Who is affected by this household appliance standard?

The standard is applicable for manufacturers of electric and electronic components in household appliances, such as terminals and switches, e.g. in:

- Dishwashers, washing machines, refrigerators
- Kitchen stoves, microwaves
- Small household appliances, such as mixers, coffee machines

Also affected is unattended equipment used in small and medium-sized enterprises, particularly:

- Pump components
- Illuminant components
- Industrial and commercial cleaning equipment
- Hair salon equipment etc.

## WECO products are compliant with the glow-wire test of the household appliance standard!

For the white goods market segment, WECO Contact GmbH offers an extensive range of PC board terminals and PC board plug connectors which meet the flame-resistance requirements of the Household Appliance Standard DIN EN/IEC 60335-1.

Molding materials used by WECO are tested and VDE-approved according to the glow-wire test requirements specified in DIN EN/IEC 60335-1. This applies for all standard WECO colors!

WECO products made of these molding materials are:

- All products with PC board connection technology, except for versions with higher number of poles such as series 95.., 96.. and 97... ,
- Terminal strips (catalogue 7), if purchased made of V-0 molding material (for unprinted versions, the part number ends with “EN6”),
- Other products. Feasibility must be checked individually.



WECO “no flame” products are designated with a small symbol on our label:



## Our customer service

WECO takes technical support and after-sale service for our customers very seriously.

For your information, we have therefore compiled a list of all manufacturer products affected by the household appliance standard on our website. At a glance, you can gather information on whether your appliances are affected or not.

The list is also a valuable tool for both our sales staff and our field reps, helping them to resolve unclear issues in project meetings, and enabling them to optimally support the customer.

# RoHS - Restriction of Hazardous Substances

## Declaration

The directive 2002/95/EC (RoHS 1) on the restriction of the use of certain hazardous substances in electrical and electronic equipment controls since 1st July 2006 the use of hazardous substances in devices and components.

The directive is generally named with the short term RoHS (Restriction of Hazardous Substances). It affects manufacturers, sellers, distributors and recyclers of electrical and electronic equipment containing mercury, cadmium, lead, chromium VI, polybrominated biphenyls (PBB) and polybrominated diphenyl ethers (PBDE).

This directive has been replaced on 3rd January 2013 by the revised version 2011/65/EU (RoHS 2). Thus, the ranges of validity of the RoHS have been extended. Earlier given exceptions are reduced step by step.

WECO Contact is a responsible manufacturer of components for electrical connection technology and thus provides products in RoHS - compliant versions since the implementation of the EU Directive 2002/95/EC in 2006. All products are now RoHS compliant since the recast 2011/65/EU.



## Labeling of our products

Customers can clearly see the RoHS Compliance of the product on the right bottom of our product labels, marked with a little icon:



## Symbols on our data sheets

---

These symbols can be found on our data sheets on the right side of the product image.



RoHS compliant  
These articles comply with  
the RoHS regulations.



„no flame“ after glow-wire test according to household appliance  
standard DIN EN/IEC 60335-1.

The housing materials used are VDE-tested and approved  
according to the glow-wire tests specified in DIN EN/IEC 60335-1.  
They meet the requirements of the household appliance standard.



This product is available in Tape-on-Reel.

Detailed information about number of poles, part numbers, tape  
width, belt height and packing units is given on the data sheet.

### ■ Legal Notice

We reserve the right to make technical as well as changes to  
measurements, colours and formats after print.

Only the values given in our written confirmations will be binding for us.

Please take notice that it is not allowed to use our photos, drawings or  
catalogue pages for your own applications without having our written  
agreement.

# Lighting applications

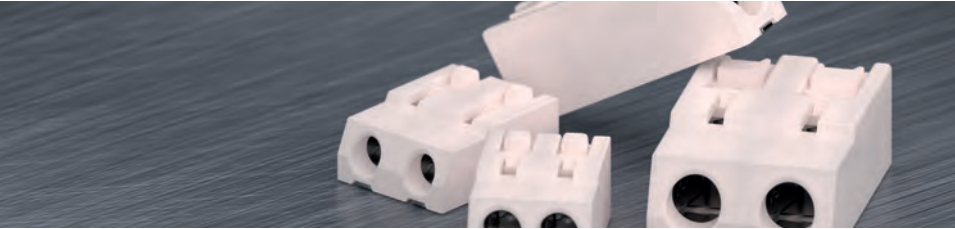

## milliLED Series 800



Pitch 3.5 mm



Lighting applications



## Lighting Technology

Light bridges create connections

Superior MTBF

Separable connections

Minimal shadowing



Modern LEDs with increasingly large lumen/watt packages require significantly lower substrate surface for the heat dissipation substrate. This allows for smaller and wider spread LED boards and ensures shadow-free light distribution.

But what if one of the PCBs fails? The quick and easy exchange and safe contacting of WECO milliLED® Series provide maximum acceptance by our customers.

No matter whether you mount LED boards in line or in a variable distance: our safe, always separable and shadow-free terminals offer the perfect connection for a long life cycle and your highest satisfaction!



### DESIGN

- Lowest assembly height
- No shadowing
- Colour fastness housings

### TECHNOLOGY

- Simple, safe and easy-to-disconnect technology rugged contact pins
- Extremely safe contact elements and funnel opening for easy cable insertion
- Designed for SMD applications

### VERSATILITY

- Developed for the most adverse conditions: UV-resistant, corrosion- and aging-resistant, isolation-optimized
- Simple, safe and easy-to-disconnect technology

# 802-A-111-SMD

PCB connector for SMD  
Push-In connection

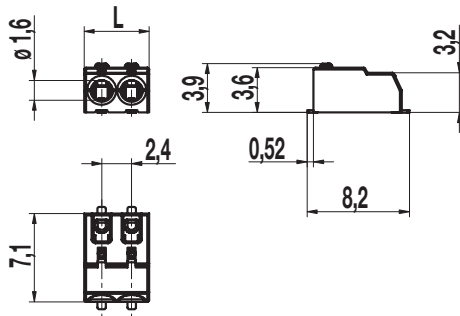

### PCB Layout (Recommendation)

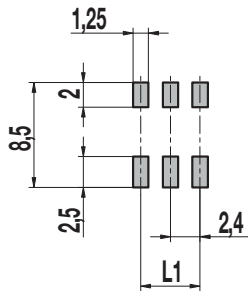

L1 = (No. of poles - 1) x pitch  
Solder paste thickness: 0,15 - 0,2 mm

### Part Numbers

No. of poles	802-A-111-SMD	Length	PU
1		3,20 mm	
2		5,20 mm	
3		7,60 mm	

### General Information

Pitch	2,4 mm
No. of poles	1 - 3
Areas of application	Lighting technology, devices

### Technical Data

Clamping Range	<i>solid / flexible / AWG</i> 0,14 - 0,34mm <sup>2</sup> / 0,14 - 0,34mm <sup>2</sup> / 26 - 22 AWG [1]		
Rated Cross Section	0,34 mm <sup>2</sup>		
Wire Stripping Length	5 mm ± 0,5 mm		
Overvoltage Category	III	III	II
Pollution Severity Level	3	2	2
Rated Voltage	125 V	160 V	320 V
Rated Impulse Voltage	2,5 kV	2,5 kV	2,5 kV
Rated Current	4 A (0,34 mm <sup>2</sup> / AWG 22) 3 A (0,2 mm <sup>2</sup> / AWG 24) 2,5 A (0,14 mm <sup>2</sup> / AWG 26)		
Soldering process	Reflow solder		

### Material

Moulding	PA HT, natural, V-0
Comparative Tracking Index	CTI ≥ 600
Insulating Group	I
Temperature Range	-40°C up to 105°C; reflow solder temperature peak max. 255°C acc. to DIN EN 61760-1
Terminal body	Tin plated copper alloy
Spring	Tin plated copper alloy

### Approvals

	Current [A]	Voltage [V]	Group	AWG	[Nm]
	3	250		26 - 22	

UL certification pending

### Part Numbers: Tape-on-Reel

No. of poles	802-A-111-SMD	Tape Width	Tape Height	PU
1	10.813.201.A00	16,0 mm	4,75 mm	1200
2	10.813.202.A00	16,0 mm	4,75 mm	1200
3	10.813.203.A00	16,0 mm	4,75 mm	1200

[1] Use of flexible conductors only with tinned ends

# 803-A-111-SMD

PCB connector for SMD  
Push-In connection

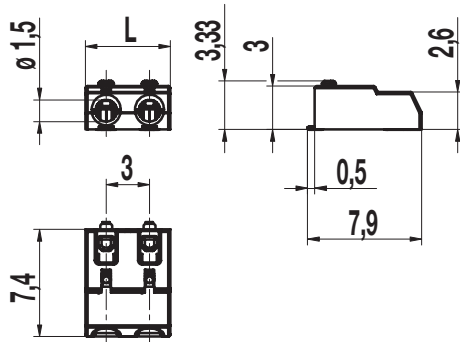

### PCB Layout (Recommendation)

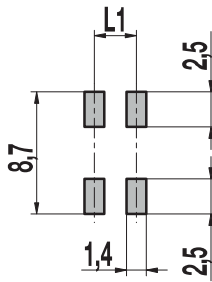

L1 = (No. of poles - 1) x pitch  
Solder paste thickness: 0,15 - 0,2 mm

### Part Numbers

No. of poles	803-A-111-SMD	Length	PU
1		2,90 mm	
2		5,90 mm	
3		8,90 mm	

### General Information

Pitch	3 mm
No. of poles	1 - 3
Areas of application	Lighting technology, devices

### Technical Data

Clamping Range	<i>solid / flexible / AWG</i> 0,14 - 0,34mm <sup>2</sup> / 0,14 - 0,34mm <sup>2</sup> / 26 - 22 AWG [1]		
Rated Cross Section	0,34 mm <sup>2</sup>		
Wire Stripping Length	5 mm ± 0,5 mm		
Overvoltage Category	III	III	II
Pollution Severity Level	3	2	2
Rated Voltage	32 V	125 V	160 V
Rated Impulse Voltage	1,5 kV	1,5 kV	1,5 kV
Rated Current	4 A (0,34 mm <sup>2</sup> / AWG 22) 3 A (0,2 mm <sup>2</sup> / AWG 24) 2,5 A (0,14 mm <sup>2</sup> / AWG 26)		
Soldering process	Reflow solder		

### Material

Moulding	PA HT, natural, V-0
Comparative Tracking Index	CTI ≥ 600
Insulating Group	I
Temperature Range	-40°C up to 105°C; reflow solder temperature peak max. 255°C acc. to DIN EN 61760-1
Terminal body	Tin plated copper alloy
Spring	Tin plated copper alloy

### Approvals

	Current [A]	Voltage [V]	Group	AWG	[Nm]
	3	250		26 - 22	

UL certification pending

### Part Numbers: Tape-on-Reel

No. of poles	803-A-111-SMD	Tape Width	Tape Height	PU
1	10.813.301.A00	16 mm	4,1 mm	2200
2	10.813.302.A00	16 mm	4,1 mm	1400
3	10.813.303.A00	16 mm	4,1 mm	1400

[1] Use of flexible conductors only with tinned ends

# 804-A-111-SMD

PCB connector for SMD  
Push-In connection

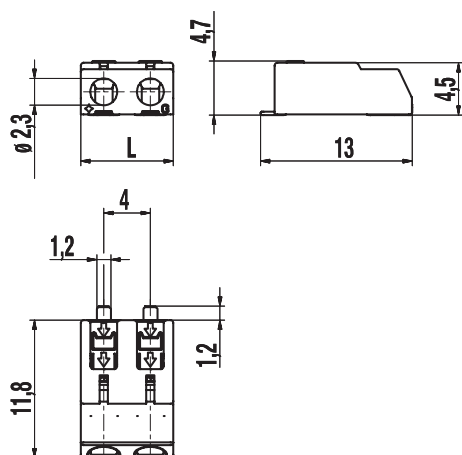

### PCB Layout (Recommendation)

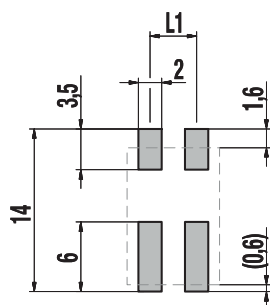

L1 = (No. of poles - 1) x pitch  
Solder paste thickness: 0,15 - 0,2 mm

### Part Numbers

No. of poles	804-A-111-SMD	Length	PU
1		3,95 mm	
2		7,95 mm	
3		11,95 mm	

### General Information

Pitch	4 mm
No. of poles	1 - 3
Areas of application	Lighting technology, devices

### Technical Data

Clamping Range	<i>solid / flexible / AWG</i> 0,2 - 0,75mm <sup>2</sup> / 0,2 - 0,75mm <sup>2</sup> / 24 - 18 AWG [1]		
Rated Cross Section	0,75 mm <sup>2</sup>		
Wire Stripping Length	6,5 mm ± 0,5 mm		
Overvoltage Category	III	III	II
Pollution Severity Level	3	2	2
Rated Voltage	32 V	125 V	160 V
Rated Impulse Voltage	1,5 kV	1,5 kV	1,5 kV
Rated Current	9 A (0,75 mm <sup>2</sup> / AWG 18)		
Soldering process	Reflow solder		

### Material

Moulding	PA HT, natural, V-0
Comparative Tracking Index	CTI ≥ 600
Insulating Group	I
Temperature Range	-40°C up to 105°C; reflow solder temperature peak max. 255°C acc. to DIN EN 61760-1
Terminal body	Tin plated copper alloy
Spring	Tin plated copper alloy

### Approvals

	Current [A]	Voltage [V]	Group	AWG	[Nm]
	9	250		24 - 18	

UL certification pending

### Part Numbers: Tape-on-Reel

No. of poles	804-A-111-SMD	Tape Width	Tape Height	PU
1	10.813.401.A00	24,0 mm	5,1 mm	1500
2	10.813.402.A00	24,0 mm	5,1 mm	1000
3	10.813.403.A00	24,0 mm	5,1 mm	750

[1] Use of flexible conductors only with tinned ends

## 830-A-111-SMD

PCB connector for SMD  
Push-In connection

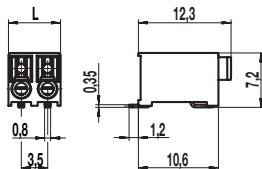

### PCB Layout (Recommendation)

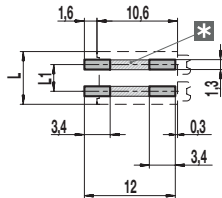

L = (No. of poles) x pitch  
L1 = (No. of poles - 1) x pitch  
Solder paste thickness: 0,15 - 0,2 mm

\* = Both solder pads of each pole can be connected together.

The PCB terminal block 830-A-111-SMD with the pitch of 3,5 mm offers strong performance in the smallest space. The position of the entries in parallel to the printed circuit board enables the advantageous application within housings with external connection. Due to the very small space requirement and the white colour it is ideally suited to various applications in the lighting industry.

The front of the terminal is equipped with pushers to be handled with standard screwdrivers for the removal of the parallel connected conductors.

The easy to use spring system allows beside the use of 1 mm<sup>2</sup> solid wires also the connection of 0,75 mm<sup>2</sup> flexible by use of the pushers.

The advanced design of this high temperature resistant terminal allows in the area of the solder pins the free circulation of hot air in the convection oven during the reflow soldering process.

The standard packaging in Tape-on-Reel makes this terminal very suitable for its automatic pick & place in the production line.

### Part Numbers: Bar magazines

No. of poles	830-A-111-SMD		Length	PU
2	10.813.002 (49 bar mag.)		6,90	3626
3	10.813.003 (49 bar mag.)		10,40	2401
2	10.813.002.B00 (4 bar mag.)		6,90	296
3	10.813.003.B00 (4 bar mag.)		10,40	196

### General Information

Pitch	3,5 mm
No. of poles	2 + 3
Areas of application	Lighting technology, devices

### Technical Data

Clamping Range	<i>solid / flexible / AWG</i>		
	0,2 - 1,0 mm <sup>2</sup> / 0,2 - 0,75 mm <sup>2</sup> / 24 - 18 AWG		
Rated Cross Section	1 mm <sup>2</sup> (starr / solid) / 0,75 mm <sup>2</sup>		
Wire Stripping Length	7,5 mm ± 0,5 mm		
Overvoltage Category	III	III	II
Pollution Severity Level	3	2	2
Rated Voltage	160 V	160 V	320 V
Rated Impulse Voltage	2,5 kV	2,5 kV	2,5 kV
Rated Insulation Voltage	130 V acc. to EN 60998-1		
Rated Current	13,5 A apply to 1 mm <sup>2</sup> solid 9 A apply to 0,75 mm <sup>2</sup>		
Soldering process	Reflow solder		

### Material

Moulding	PA HT, white, V-0
Comparative Tracking Index	CTI ≥ 600
Insulating Group	I
Temperature Range	-40°C up to 120°C; reflow solder temperature peak max. 255°C acc. to DIN EN 61760-1
Terminal body	Tin plated copper alloy
Spring	Stainless steel

### Approvals

	Current [A]	Voltage [V]	Group	AWG	[Nm]
	6	300	B	24 - 18	

### Options / Accessories

- Consecutive numbering
- Special marking according to drawing
- Black colour on request

### Part Numbers: Tape-on-Reel

No. of poles	830-A-111-SMD	Tape Width	Tape Height	PU
2	10.813.002.A00	24 mm	8,4 mm	550
3	10.813.003.A00	24 mm	8,4 mm	550

# 830-A-121-SMD

PCB connector for SMD  
Push-In connection vertical to PCB

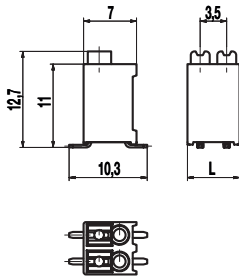

### PCB Layout (Recommendation)

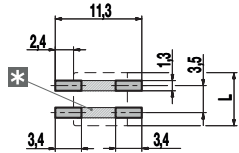

L = (No. of poles) x pitch  
L1 = (No. of poles - 1) x pitch  
Solder paste thickness: 0,15 - 0,2 mm

\* = Both solder pads of each pole can be connected together.

The PCB terminal block 830-A-121-SMD with the pitch of 3,5 mm offers strong performance in the smallest space. It is available in 2- and 3-pole design. The position of the entries in vertical to the printed circuit board enables the advantageous application within housings with external connection. Due to the very small space requirement and the white colour it is ideally suited to various applications in the lighting industry.

The top of the terminal is equipped with pushers to be handled with standard screwdrivers for the removal of the parallel connected conductors.

The easy to use spring system allows beside the use of 1 mm<sup>2</sup> solid wires also the connection of 0,75 mm<sup>2</sup> flexible by use of the pushers.

The advanced design of this high temperature resistant terminal allows in the area of the solder pins the free circulation of hot air in the convection oven during the reflow soldering process.

This product is suitable for its automatic pick & place in the production line.

### Part Numbers

No. of poles	830-A-121-SMD	Length	PU
2	10.813.032.B00 (1 bar mag.)	6,90	75
3	10.813.033.B00 (1 bar mag.)	10,40	50

### General Information

Pitch	3,5 mm
No. of poles	2 + 3
Areas of application	Lighting technology, devices

### Technical Data

Clamping Range	<i>solid / flexible / AWG</i> 0,2 - 1,0 mm <sup>2</sup> / 0,2 - 0,75 mm <sup>2</sup> / 24 - 18 AWG		
Rated Cross Section	1 mm <sup>2</sup> (starr / solid) / 0,75 mm <sup>2</sup>		
Wire Stripping Length	7,5 mm ± 0,5 mm		
Overvoltage Category	III	III	II
Pollution Severity Level	3	2	2
Rated Voltage	160 V	160 V	320 V
Rated Impulse Voltage	2,5 kV	2,5 kV	2,5 kV
Rated Insulation Voltage	130 V acc. to EN 60998-1		
Rated Current	13,5 A apply to 1 mm <sup>2</sup> solid 9 A apply to 0,75 mm <sup>2</sup>		
Soldering process	Reflow solder		

### Material

Moulding	PA HT, white, V-0
Comparative Tracking Index	CTI ≥ 600
Insulating Group	I
Temperature Range	-40°C up to 120°C; reflow solder temperature peak max. 255°C acc. to DIN EN 61760-1
Terminal body	Tin plated copper alloy
Spring	Stainless steel

### Approvals

	Current [A]	Voltage [V]	Group	AWG	[Nm]
	6	300	B	24 - 18	

### Options / Accessories

- Black colour on request
- Tape-on-Reel on request

### Part Numbers: Tape-on-Reel

No. of poles	830-A-121-SMD	Tape Width	Tape Height	PU
2	10.813.032.A00	24 mm	14,4 mm	300
3	10.813.033.A00	24 mm	14,4 mm	300

# 830-A-111-THR

PCB connector for SMD  
Push-In connection

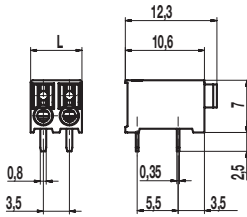

## PCB Layout (Recommendation)

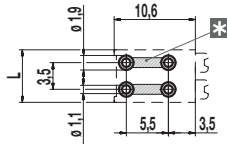

L = (No. of poles) x pitch  
L1 = (No. of poles - 1) x pitch  
Solder paste thickness: 0,15 - 0,2 mm  
solder pad, outside diameter:  $\varnothing$  1,9 mm

\* = Both solder pads of each pole can be connected together.

The PCB terminal block 830-A-111-THR with the pitch of 3,5 mm offers strong performance in the smallest space. The position of the entries in parallel to the printed circuit board enables the advantageous application within housings with external connection. Due to the very small space requirement and the white colour it is ideally suited to various applications in the lighting industry.

The front of the terminal is equipped with pushers to be handled with standard screwdrivers for the removal of the parallel connected conductors.

The easy to use spring system allows beside the use of 1 mm<sup>2</sup> solid wires also the connection of 0,75 mm<sup>2</sup> flexible by use of the pushers.

The advanced design of this high temperature resistant terminal allows in the area of the solder pins the free circulation of hot air in the convection oven during the reflow soldering process.

## Part Numbers

No. of poles	830-A-111-THR	Length	PU
2	10.813.052	6,90	250
3	10.813.053	10,40	250
2	10.813.052.B00 (2 bar mag.)	6,90	150
3	10.813.053.B00 (2 bar mag.)	10,40	100

## General Information

Pitch	3,5 mm
No. of poles	2 + 3
Areas of application	Lighting technology, devices

## Technical Data

Clamping Range	<i>solid / flexible / AWG</i>		
	0,2 - 1,0 mm <sup>2</sup> / 0,2 - 0,75 mm <sup>2</sup> / 24 - 18 AWG		
Rated Cross Section	1 mm <sup>2</sup> (starr / solid) / 0,75 mm <sup>2</sup>		
Wire Stripping Length	7,5 mm $\pm$ 0,5 mm		
Overvoltage Category	III	III	II
Pollution Severity Level	3	2	2
Rated Voltage	160 V	160 V	320 V
Rated Impulse Voltage	2,5 kV	2,5 kV	2,5 kV
Rated Insulation Voltage	130 V acc. to EN 60998-1		
Rated Current	13,5 A apply to 1 mm <sup>2</sup> solid 9 A apply to 0,75 mm <sup>2</sup>		
Soldering process	Reflow solder		
Hole in PCB	$\varnothing$ 1,1 mm		

## Material

Moulding	PA HT, white, V-0
Comparative Tracking Index	CTI $\geq$ 600
Insulating Group	I
Temperature Range	-40°C up to 120°C; reflow solder temperature peak max. 255°C acc. to DIN EN 61760-1
Terminal body	Tin plated copper alloy
Spring	Stainless steel

## Approvals

	Current [A]	Voltage [V]	Group	AWG	[Nm]
	6	300	B	24 - 18	

## Options / Accessories

- Consecutive numbering
- Special marking according to drawing
- Black colour on request
- Tape-on-Reel on request

# 830-A-121-THR

PCB connector for SMD  
Push-In connection vertical to PCB

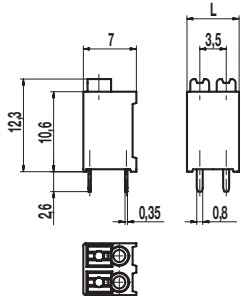

### PCB Layout (Recommendation)

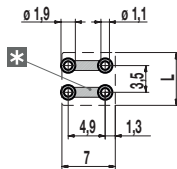

L = (No. of poles) x pitch  
L1 = (No. of poles - 1) x pitch  
Solder paste thickness: 0,15 - 0,2 mm  
solder pad, outside diameter:  $\varnothing$  1,9 mm

\* = Both solder pads of each pole can be connected together.

The PCB terminal block 830-A-121-THR with the pitch of 3,5 mm offers strong performance in the smallest space. It is available in 2- and 3-pole design. The position of the entries vertical to the printed circuit board enables the advantageous application within housings with external connection. Due to the very small space requirement and the white colour it is ideally suited to various applications in the lighting industry.

The front of the terminal is equipped with pushers to be handled with standard screwdrivers for the removal of the parallel connected conductors.

The easy to use spring system allows beside the use of 1 mm<sup>2</sup> solid wires also the connection of 0,75 mm<sup>2</sup> flexible by use of the pushers.

The advanced design of this high temperature resistant terminal allows in the area of the solder pins the free circulation of hot air in the convection oven during the reflow soldering process.

### Part Numbers

No. of poles	830-A-121-THR	Length	PU
2	10.813.082	6,90	250
3	10.813.083	10,40	250
2	10.813.082.B00 (1 bar mag.)	6,90	75
3	10.813.083.B00 (1 bar mag.)	10,40	50

### General Information

Pitch	3,5 mm
No. of poles	2 + 3
Areas of application	Lighting technology, devices

### Technical Data

Clamping Range	<i>solid / flexible / AWG</i> 0,2 - 1,0 mm <sup>2</sup> / 0,2 - 0,75 mm <sup>2</sup> / 24 - 18 AWG		
Rated Cross Section	1 mm <sup>2</sup> (starr / solid) / 0,75 mm <sup>2</sup>		
Wire Stripping Length	7,5 mm $\pm$ 0,5 mm		
Overvoltage Category	III	III	II
Pollution Severity Level	3	2	2
Rated Voltage	160 V	160 V	320 V
Rated Impulse Voltage	2,5 kV	2,5 kV	2,5 kV
Rated Insulation Voltage	130 V acc. to EN 60998-1		
Rated Current	13,5 A apply to 1 mm <sup>2</sup> solid 9 A apply to 0,75 mm <sup>2</sup>		
Soldering process	Wave solder & reflow solder		
Hole in PCB	$\varnothing$ 1,1 mm		

### Material

Moulding	PA HT, white, V-0
Comparative Tracking Index	CTI $\geq$ 600
Insulating Group	I
Temperature Range	-40°C up to 120°C; reflow solder temperature peak max. 255°C acc. to DIN EN 61760-1
Terminal body	Tin plated copper alloy
Spring	Stainless steel

### Approvals

	Current [A]	Voltage [V]	Group	AWG	[Nm]
	6	300	B	24 - 18	

### Options / Accessories

- Black colour on request
- Tape-on-Reel on request

### Part Numbers: Tape-on-Reel

No. of poles	830-A-121-THR	Tape Width	Tape Height	PU
2	10.813.082.A00	24 mm	17,2 mm	300
3	10.813.083.A00	24 mm	17,2 mm	300



## 931-SLT-SMD-1,1-L4

Pin strip for SMD

Low profile, 4 mm height

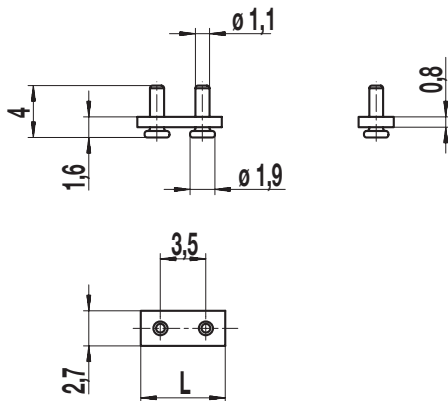
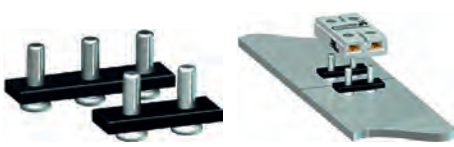

### Recommended PCB Layout

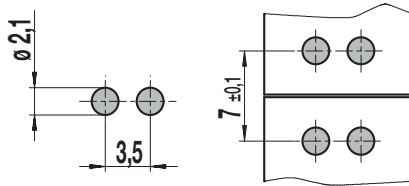

Solder paste thickness: 0,15 - 0,2 mm

The pin strip 931-SLR-SMD-1,1-L4 with only 4 mm height is the perfect solution to connect in combination with the PCB connector 930-LC-111 two adjacent LED boards with each other.

With this product, the height on the board is kept as small as possible at the same time.

The pin strip is suitable for surface mounting and is delivered in Tape-on-Reel with Pick Cap.

### Part Numbers

No. of poles	931-SLT-SMD-1,1-L4	Length	PU
2	12.893.719	6,5	250
3	13.893.719	10,0	500

### General Information

Pitch	3,5 mm
No. of poles	2 + 3
Usable with	930-LC-111, 930-LP-111
Areas of application	LED Panel bridging

### Technical Data

Overvoltage Category	III	III	II
Pollution Severity Level	3	2	2
Rated Voltage	160 V	160 V	320 V
Rated Impulse Voltage	2,5 kV	2,5 kV	2,5 kV
Rated Insulation Voltage	130 V acc. to EN 60998-1		
Rated Current	6 A		
Soldering process	Reflow solder		

### Material

Moulding	PA HT, black, V-0
Comparative Tracking Index	CTI $\geq$ 600 V
Insulating Group	I
Temperature Range	-40°C up to 120°C; reflow solder temperature peak max. 255°C acc. to DIN EN 61760-1
Solder pin	$\phi$ 1,1 mm; tin plated brass

### Approvals

	Current [A]	Voltage [V]	Group	AWG	[Nm]
	6 [1]	250			

[1] Acc. to UL 1977 and C22.2 No. 182.3

### Part Numbers: Tape-on-Reel

No. of poles	931-SLT-SMD-1,1-L4	Tape Width	Tape Height	PU
2	12.893.719.A00	24 mm	6,6 mm	900
3	13.893.719.A00	24 mm	6,6 mm	900

# PCB connectors

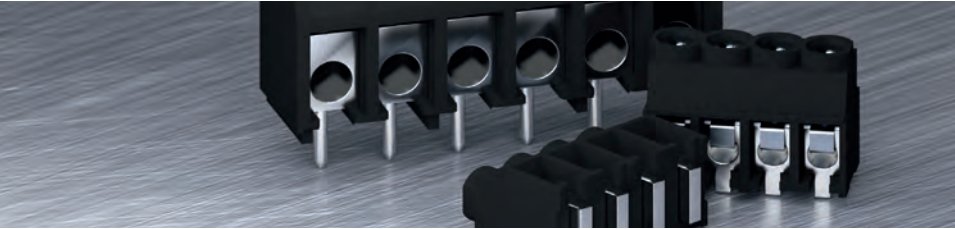

## SMD

Pitch 3.5 mm	 210-A-SMD <b>20</b>	 210-A-126-SMD <b>21</b>	 930-D-SMD-DS <b>22</b>	
	 140-A-SMD <b>23</b>	 140-A-126-SMD <b>24</b>	 950-D-SMD-DS <b>25</b>	 974-D-SMD-DS <b>26</b>

## THR

Pitch 3.5 mm	 210-A-111-THR <b>28</b>	 930-THR <b>28</b>	 934-THR-DS <b>29</b>
	 140-A-111-THR <b>30</b>	 950-THR <b>31</b>	 970-THR <b>32</b>

PCB connectors

## 210-A-SMD

PCB connector for SMD

Screw connection, with anti-twist peg

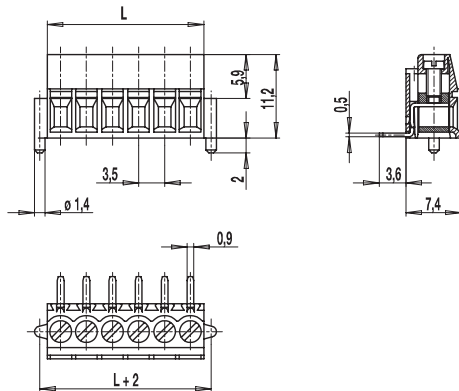

L = No. of poles x pitch

### PCB Layout

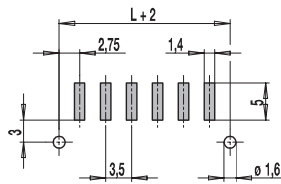

Solder paste thickness: 0,2 mm

The PCB connectors for surface mounting comprise several types for reflow processes.

The SMD connector 210-A-SMD with a pitch of 3,5 mm is designed with screw connections in elevator clamping style and available in 2 to 12 pole design.

The terminal clamp and the soldering tag are manufactured as a single unit and permanently engaged in the housing. The solder pins are exactly aligned parallel to the printed circuit board in order to create a coplanar connection after the reflow soldering process.

The moulding is made of heat resistant thermoplastic material and equipped with plastic pegs on both sides to prevent twisting.

The use of a strain relief is recommended. This article is only available in tubes or in Tape-on-Reel.

### Part Numbers

No. of poles	210-A-SMD	Length	PU
2	10.804.202	7,00	900
3	10.804.203	10,50	684
4	10.804.204	14,00	540
5	10.804.205	17,50	450
6	10.804.206	21,00	378
8	10.804.208	28,00	288
10	10.804.210	35,00	234
12	10.804.212	42,00	198

further number of poles on request

### General Information

Pitch	3,5 mm
No. of poles	2 - 12



### Technical Data

Clamping Range	<i>solid / flexible / AWG</i>		
	0,14 - 1,5 mm <sup>2</sup> / 0,14 - 1,5 mm <sup>2</sup> / 30 - 16 AWG		
Rated Cross Section	1 mm <sup>2</sup>		
Wire Stripping Length	5,5 mm ± 0,5 mm		
Overvoltage Category	III	III	II
Pollution Severity Level	3	2	2
Rated Voltage	160 V	160 V	320 V
Rated Impulse Voltage	2,5 kV	2,5 kV	2,5 kV
Rated Insulation Voltage	130 V acc. to EN 60998-1		
Rated Current	12,5 A		
Soldering process	Reflow solder		
Torque	0,2 Nm		

### Material

Moulding	PA HT, black, V-0
Comparative Tracking Index	CTI ≥ 600
Insulating Group	I
Temperature Range	-40°C up to 120°C; reflow solder temperature peak max. 255°C acc. to DIN EN 61760-1
Terminal body	Nickel plated brass
Pressure clamp	Copper alloy, tin plated
Screw	M2; Copper alloy, tin plated
Solder pin	Copper alloy, tin plated

### Approvals

	Current [A]	Voltage [V]	Group	AWG	[Nm]
	10	300	B	30 - 16	0,23
	10	300	B	30 - 16	0,22
					

### Options / Accessories

- Consecutive numbering
- Special marking according to drawing
- Self-adhesive marking strip BST-3,50 [1]

### Part Numbers: Tape-on-Reel

No. of poles	210-A-SMD	Tape Width	Tape Height	PU
2	10.804.202.A00	44 mm	14,6 mm	325
3	10.804.203.A00	44 mm	14,6 mm	325
4	10.804.204.A00	44 mm	14,6 mm	325
5	10.804.205.A00	44 mm	14,6 mm	325
6	10.804.206.A00	44 mm	14,6 mm	325
7	10.804.207.A00	44 mm	14,6 mm	325

further number of poles on request

[1] To be fitted after reflow soldering process

## 210-A-126-SMD

PCB connector for SMD

Screw connection, with solder flanges

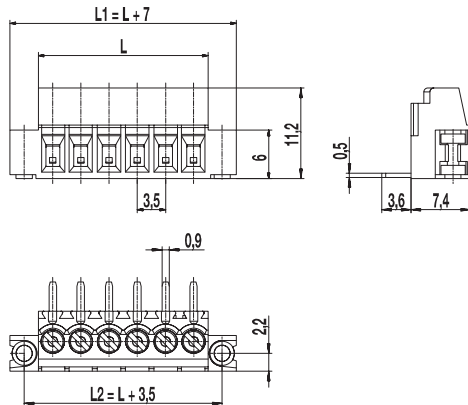

L = No. of poles x pitch

### PCB Layout

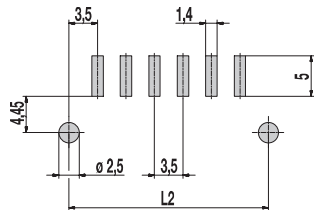

Solder paste thickness: 0,2 mm

The 2 to 12 pole connectors with a pitch of 3,5 mm have a screw connection with elevator clamping system and are equipped with M2 captive screws. Just as the 210-A-SMD, the 210-A-126-SMD represents a space saving and compact connector with a high connecting capacity. The generous clamping range is of 1,7 mm x 2,6 mm.

A distinguishing characteristic to the 210-A-SMD, however, is the clearly increased adhesion force on the PCB. Soldering cylinders on either side of the housing (floating anchors) are movable in vertical direction and thereby they obtain 100% coplanarity between solder pins and soldering cylinders.

They are transferred more to the front in comparison to the connector centre in order to keep the retaining strength, where the wires are connected. Thus, the force, acting on the solder pins, is reduced in a very important way.

Packed in magazines or equipped with Pick Discs in Tape-on-Reel, this genuine SMD terminal is suitable for the automatic assembly.

### Part Numbers

No. of poles	210-A-126-SMD	Length	PU
2	20.804.232	14,00	888
3	20.804.233	17,50	696
4	20.804.234	21,00	576
6	20.804.236	28,00	432
10	20.804.240	42,00	234
12	20.804.242	49,00	198

further number of poles on request

### General Information

Pitch	3,5 mm
No. of poles	2 - 12



### Technical Data

Clamping Range	<i>solid / flexible / AWG</i>		
	0,14 - 1,5 mm <sup>2</sup> / 0,14 - 1,5 mm <sup>2</sup> / 30 - 16 AWG		
Rated Cross Section	1 mm <sup>2</sup>		
Wire Stripping Length	5,5 mm ± 0,5 mm		
Overvoltage Category	III	III	II
Pollution Severity Level	3	2	2
Rated Voltage	160 V	160 V	320 V
Rated Impulse Voltage	2,5 kV	2,5 kV	2,5 kV
Rated Insulation Voltage	130 V acc. to EN 60998-1		
Rated Current	12,5 A		
Soldering process	Reflow solder		
Torque	0,2 Nm		

### Material

Moulding	PA HT, black, V-0
Comparative Tracking Index	CTI ≥ 600
Insulating Group	I
Temperature Range	-40°C up to 120°C; reflow solder temperature peak max. 255°C acc. to DIN EN 61760-1
Terminal body	Nickel plated brass
Pressure clamp	Copper alloy, tin plated
Screw	M2; copper alloy, tin plated
Solder pin	Copper alloy, tin plated
Solder cylinder	Tin plated brass

### Approvals

	Current [A]	Voltage [V]	Group	AWG	[Nm]
	10	300	B	30 - 16	0,23
	10	300	B	30 - 16	0,22
					

### Options / Accessories

- Self-adhesive marking strip BST-3,50 [1]
- White housing colour on request

### Part Numbers: Tape-on-Reel

No. of poles	210-A-126-SMD	Tape Width	Tape Height	PU
2	20.804.232.A00	32 mm	12,0 mm	375
3	20.804.233.A00	44 mm	14,6 mm	325
4	20.804.234.A00	44 mm	14,6 mm	325
5	20.804.235.A00	44 mm	14,6 mm	325
6	20.804.236.A00	44 mm	14,6 mm	325
8	20.804.238.A00	56 mm	14,6 mm	325

further number of poles on request

[1] To be fitted after reflow soldering process

## 930-D-SMD(-DS)

PCB connector for SMD

Screw connection, floating terminal bodies

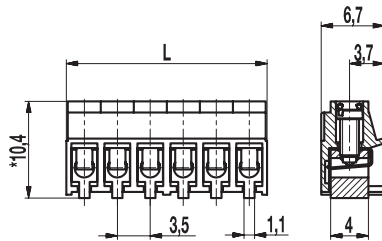

\* = Height without -DS: 10,2 mm  
L = No. of poles x pitch + 0,3 mm

### PCB Layout

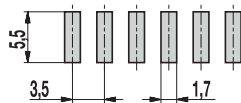

Solder paste thickness: 0,15 - 0,2 mm

The PCB connector 930-D-SMD with a pitch of 3,5 mm for genuine surface mount technology is specifically designed for automated processing assembly and is available in 2 to 12 pole design.

In the Tape-on-Reel packaging, it is equipped with a glued pick disc that can be easily removed after the soldering process.

Its floating terminal bodies compensate irregularities (non planarity and bumps) on the printed circuit board.

The same feature eliminates CTE (coefficient of thermal expansion) mismatch with the PCB and thus promotes excellent in field reliability and the successful passing of thermal cycling testing.

### Part Numbers

No. of poles	930-D-SMD	930-D-SMD-DS	Length	PU
2	10.870.602	20.870.602	7,30	250
3	10.870.603	20.870.603	10,80	250
4	10.870.604	20.870.604	14,30	250
5	10.870.605	20.870.605	17,80	200
6	10.870.606	20.870.606	21,30	200
7	10.870.607	20.870.607	24,80	100
8	10.870.608	20.870.608	28,30	100
9	10.870.609	20.870.609	31,80	100
10	10.870.610	20.870.610	35,30	100
11	10.870.611	20.870.611	38,80	100
12	10.870.612	20.870.612	42,30	100

### General Information

Pitch	3,5 mm
No. of poles	2 - 12



### Technical Data

Clamping Range	<i>solid / flexible / AWG</i>		
<i>without wire protector</i>	0,75 - 1,5 mm <sup>2</sup> / 0,75 - 1,5 mm <sup>2</sup> / 18 - 16 AWG		
<i>with wire protector</i>	0,25 - 1 mm <sup>2</sup> / 0,25 - 1 mm <sup>2</sup> / 24 - 18 AWG		
Rated Cross Section	1 mm <sup>2</sup>		
Wire Stripping Length	5 mm ± 0,5 mm		
Overvoltage Category	III	III	II
Pollution Severity Level	3	2	2
Rated Voltage	125 V	160 V	320 V
Rated Impulse Voltage	2,5 kV	2,5 kV	2,5 kV
Rated Insulation Voltage	130 V acc. to EN 60998-1		
Rated Current	13,5 A		
Soldering process	Reflow solder		
Torque	0,2 Nm		
Other specifications	Recommended screwdriver: blade 0,4 x 2,0 mm		

### Material

Moulding	PA HT, black, V-0
Comparative Tracking Index	CTI ≥ 600
Insulating Group	I
Temperature Range	-40°C up to 120°C; reflow solder temperature peak max. 255°C acc. to DIN EN 61760-1
Terminal body	Tin plated brass
Screw	M2; tin plated brass
Wire protector	German silver

### Approvals

	Current [A]	Voltage [V]	Group	AWG	[Nm]
	10	150	B	26 - 16	0,23
	10	150	B	26 - 16	0,2

### Options / Accessories

- Special marking according to drawing
- Self-adhesive marking strip BST-3,50 [1]
- White housing colour on request

### Part Numbers: Tape-on-Reel

No. of poles	930-D-SMD	930-D-SMD-DS	Tape Width	Tape Height	PU
2	10.870.602.A00	20.870.602.A00	24 mm	11,3 mm	500
3	10.870.603.A00	20.870.603.A00	24 mm	11,3 mm	500
4	10.870.604.A00	20.870.604.A00	24 mm	11,3 mm	500
5	10.870.605.A00	20.870.605.A00	32 mm	11,3 mm	500
6	10.870.606.A00	20.870.606.A00	44 mm	11,3 mm	500
12	10.870.612.A00	20.870.612.A00	56 mm	11,3 mm	500

further number of poles on request

[1] To be fitted after reflow soldering process

# 140-A-SMD

PCB connector for SMD

Screw connection, with anti-twist peg

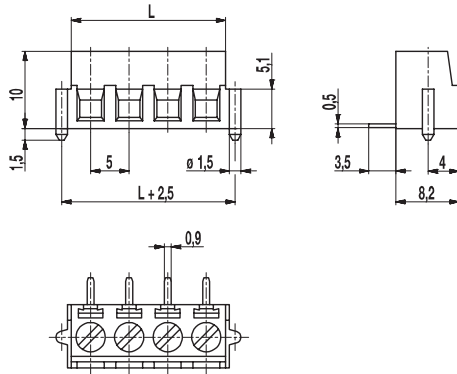

## PCB Layout

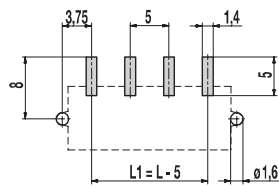

Solder paste thickness: 0,2 mm

The 2 to 8 pole terminal 140-A-SMD with a pitch of 5 mm has a screw connection with elevator clamping system and is equipped with M3 captive screws. The wire clamp and soldering tag are manufactured as a single unit and permanently engaged in the housing. The solder pins are exactly aligned parallel to the printed circuit board in order to create a coplanar connection after the reflow soldering process.

The moulding is made of heat resistant thermoplastic material and equipped with plastic pegs on both sides to prevent twisting.

This article is only available in bar magazines or in Tape-on-Reel. When delivered in Tape-on-Reel, this product is equipped with a Pick Discs that can be easily removed after the soldering process.

## Part Numbers

No. of poles	140-A-SMD	Length	PU
2	10.801.602	10,00	1036
3	10.801.603	15,00	756
4	10.801.604	20,00	588
5	10.801.605	25,00	504
6	10.801.606	30,00	420
7	10.801.607	35,00	364
8	10.801.608	40,00	308

## General Information

Pitch	5 mm
No. of poles	2 - 8



## Technical Data

Clamping Range	<i>solid / flexible / AWG</i> 0,14 - 2,5 mm <sup>2</sup> / 0,14 - 1,5 mm <sup>2</sup> / 26 - 16 AWG		
Rated Cross Section	1,5 mm <sup>2</sup>		
Wire Stripping Length	6 mm ± 0,5 mm		
Overvoltage Category	III	III	II
Pollution Severity Level	3	2	2
Rated Voltage	200 V	320 V	500 V
Rated Impulse Voltage	4 kV	4 kV	4 kV
Rated Insulation Voltage	250 V acc. to EN 60998-1		
Rated Current	16 A		
Soldering process	Reflow solder		
Torque	0,5 Nm		

## Material

Moulding	PA HT, black, V-0
Comparative Tracking Index	CTI ≥ 600
Insulating Group	I
Temperature Range	-40°C up to 120°C; reflow solder temperature peak max. 255°C acc. to DIN EN 61760-1
Terminal body	Nickle plated brass
Pressure clamp	Tin plated tin bronze
Screw	M3; zinc plated steel, blue passivated
Solder pin	0,5 x 0,9 mm; tin plated tin bronze

## Approvals

	Current [A]	Voltage [V]	Group	AWG	[Nm]
	10 [1]	300	B, D	30 - 14	0,51
	15	300	B	30 - 14	0,51

## Options / Accessories

- Consecutive numbering
- Special marking according to drawing
- Self-adhesive marking strip BST-5,00 [2]
- Version without anti-twist peg or with other fastening flanges

## Part Numbers: Tape-on-Reel

No. of poles	140-A-SMD	Tape Width	Tape Height	PU
2	10.801.602.A00	32 mm	13 mm	375
3	10.801.603.A00	56 mm	13 mm	375
4	10.801.604.A00	56 mm	13 mm	375
5	10.801.605.A00	56 mm	13 mm	375
6	10.801.606.A00	56 mm	13 mm	375

further number of poles on request

[1] 20 A max for factory-wiring applications only

[2] To be fitted after reflow soldering process

# 140-A-126-SMD

PCB connector for SMD

Screw connection, with solder flanges

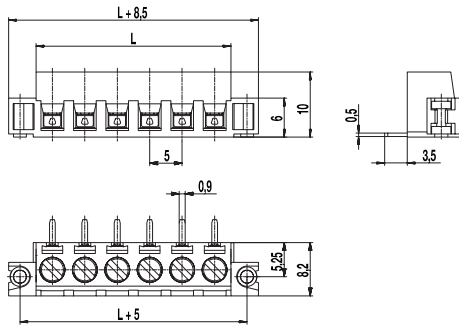

## PCB Layout

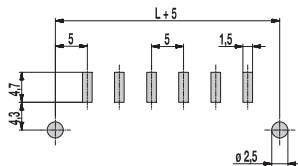

Solder paste thickness: 0,2 mm

The 2 to 8 pole terminal 140-A-126-SMD with a pitch of 5 mm has a screw connection with elevator clamping system and is equipped with M3 captive screws. The wire clamp and soldering tag are manufactured as a single unit and permanently engaged in the casing.

Soldering cylinders on either side of the housing are movable in vertical direction (floating anchors), and thereby they obtain 100% coplanarity between solder pins and soldering cylinders. They are transferred more to the front in comparison to the connector centre in order to keep the retaining strength, where the wires are connected. Thus, the force, acting on the solder pins, is reduced in a very important way.

This article is only available in bar magazines or in Tape-on-Reel. When delivered in Tape-on-Reel, this product is equipped with a Pick Discs that can be easily removed after the soldering process.

## Part Numbers

No. of poles	140-A-126-SMD	Length	PU
2	20.801.632	10,00	784
3	20.801.633	15,00	616
4	20.801.634	20,00	504
5	20.801.635	25,00	420
6	20.801.636	30,00	364
7	20.801.637	35,00	336
8	20.801.638	40,00	280

## General Information

Pitch	5 mm
No. of poles	2 - 8
Areas of application	Systems for measurement and control



## Technical Data

Clamping Range	<i>solid / flexible / AWG</i> 0,14 - 2,5 mm <sup>2</sup> / 0,14 - 1,5 mm <sup>2</sup> / 26 - 16 AWG		
Rated Cross Section	1,5 mm <sup>2</sup>		
Wire Stripping Length	6 mm ± 0,5 mm		
Overvoltage Category	III	III	II
Pollution Severity Level	3	2	2
Rated Voltage	200 V	320 V	500 V
Rated Impulse Voltage	4 kV	4 kV	4 kV
Rated Insulation Voltage	250 V acc. to EN 60998-1		
Rated Current	16 A		
Soldering process	Reflow solder		
Torque	0,5 Nm		

## Material

Moulding	PA HT, black, V-0
Comparative Tracking Index	CTI ≥ 600
Insulating Group	I
Temperature Range	-40°C up to 120°C; reflow solder temperature peak max. 255°C acc. to DIN EN 61760-1
Terminal body	Nickel plated brass
Pressure clamp	Tin plated tin bronze
Screw	M3; zinc plated steel, blue passivated
Solder pin	0,9 x 0,5 mm; tin plated tin bronze
Solder cylinder	Tin plated brass

## Approvals

	Current [A]	Voltage [V]	Group	AWG	[Nm]
	10 [1]	300	B, D	30 - 14	0,51
	15	300	B	30 - 14	0,51

## Options / Accessories

- Consecutive numbering
- Special marking according to drawing
- Self-adhesive marking strip BST-5,00 [2]

## Part Numbers: Tape-on-Reel

No. of poles	140-A-126-SMD	Tape Width	Tape Height	PU
2	20.801.632.A00	32 mm	13 mm	375
3	20.801.633.A00	56 mm	13 mm	375
4	20.801.634.A00	56 mm	13 mm	375
5	20.801.635.A00	56 mm	13 mm	375
6	20.801.636.A00	56 mm	13 mm	375

further number of poles on request

- [1] 20 A max for factory-wiring applications only  
[2] To be fitted after reflow soldering process

## 950-D-SMD-DS

PCB connector for SMD  
Screw connection

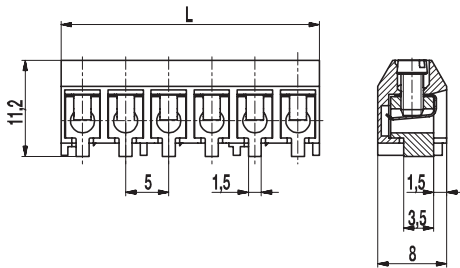

### PCB Layout

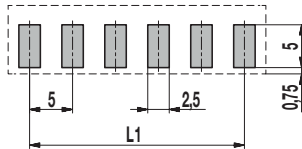

$L1 = (\text{No. of poles} - 1) \times \text{pitch}$   
Solder paste thickness: 0,15 - 0,2 mm

The reflow solderable PCB connector 950-D-SMD-DS for true surface mounting with a pitch of 5 mm is available in 2 to 12 pole design.

The geometry of the terminal body creates enough space for the solder paste and it also enables a good heat circulation for flawless soldering and an optical solder joint inspection.

The housing is made of high temperature material. Its design ensures a good hot-air circulation during the reflow soldering process in a convection oven.

The connection side of this product should be positioned in the direction of passage.

### Part Numbers

No. of poles	950-D-SMD-DS	Length	PU
2	20.879.502	10,00	250
3	20.879.503	15,00	250
4	20.879.504	20,00	100
5	20.879.505	25,00	100
6	20.879.506	30,00	100
7	20.879.507	35,00	100
8	20.879.508	40,00	100
9	20.879.509	45,00	100
10	20.879.510	50,00	100
11	20.879.511	55,00	100
12	20.879.512	60,00	100

### General Information

Pitch	5 mm
No. of poles	2 - 12



### Technical Data

Clamping Range	<i>solid / flexible / AWG</i>		
<i>with wire protector</i>	0,34 - 2,5 mm <sup>2</sup> / 0,34 - 2,5 mm <sup>2</sup> / 22 - 14 AWG		
Rated Cross Section	1,5 mm <sup>2</sup>		
Wire Stripping Length	6 mm ± 0,5 mm		
Overvoltage Category	III	III	II
Pollution Severity Level	3	2	2
Rated Voltage	160 V	160 V	320 V
Rated Impulse Voltage	2,5 kV	2,5 kV	2,5 kV
Rated Insulation Voltage	130 V acc. to EN 60998-1		
Rated Current	17,5 A		
Soldering process	Reflow solder		
Torque	0,4 Nm		

### Material

Moulding	PA HT, black, V-0
Comparative Tracking Index	CTI ≥ 600
Insulating Group	I
Temperature Range	-40°C up to 120°C; reflow solder temperature peak max. 255°C acc. to DIN EN 61760-1
Terminal body	Tin plated brass
Screw	M2,6; zinc plated steel, blue passivated
Wire protector	Tin plated tin bronze

### Approvals

	Current [A]	Voltage [V]	Group	AWG	[Nm]
	15	300	B	26 - 14	0,4
	15	300	B	26 - 14	0,4

### Options / Accessories

- Consecutive numbering
- Special marking according to drawing
- Self-adhesive marking strip BST-5,00 [1]
- Special packaging on request: Tray - Bar magazine

### Part Numbers: Tape-on-Reel

No. of poles	950-D-SMD-DS	Tape Width	Tape Height	PU
2	20.879.502.A00	32 mm	12,3 mm	500
3	20.879.503.A00	44 mm	12,0 mm	500
4	20.879.504.A00	44 mm	12,0 mm	500
5	20.879.505.A00	44 mm	12,0 mm	500
6	20.879.506.A00	56 mm	12,0 mm	500
7	20.879.507.A00	56 mm	12,0 mm	500
8	20.879.508.A00	56 mm	12,0 mm	500

[1] To be fitted after reflow soldering process



## 974-D-SMD-DS

PCB connector for SMD  
Screw connection 45°-angle to PCB

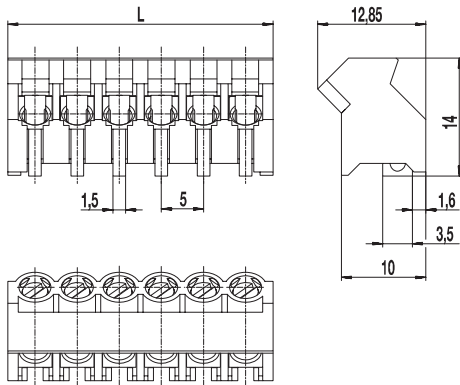

$L = \text{pole length} \times \text{pitch} + 1,5 \text{ mm}$

### PCB Layout

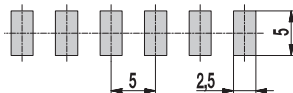

Solder paste thickness: 0,2 - 0,25 mm

By creating the 974-D-SMD-DS, WECO offers a PCB terminal for the reflow soldering process with a pitch of 5 mm in true surface mount technology. The wire entry has a connection angle of 45° to the PCB. This offers the advantage that terminal rows can be located space savingly one behind the other. The housing material consists of high temperature resistant plastic and is specially designed in order to assure a good hot-air circulation during the reflow soldering process in the convection oven. The wire entry side of the terminal has to be placed in flowing direction.

The screws are turned in to the optimal length of engagement by the factory. It is not to be excluded that the position of the screws may change by transport. Therefore it can be necessary that the screw has to be turned back for using the maximum permissible wire cross-section.

### Part Numbers

No. of poles	974-D-SMD-DS	Length	PU
2	20.874.402	11,5	250
3	20.874.403	16,5	250
4	20.874.404	21,5	200
5	20.874.405	26,5	100
6	20.874.406	31,5	100

further number of poles on request

### General Information

Pitch	5 mm
No. of poles	2 - 6



### Technical Data

Clamping Range	<i>solid / flexible / AWG</i>		
	0,75 - 4 mm <sup>2</sup> / 0,75 - 2,5 mm <sup>2</sup> / 18 - 12 AWG		
Rated Cross Section	2,5 mm <sup>2</sup>		
Wire Stripping Length	6 mm ± 0,5 mm		
Overvoltage Category	III	III	II
Pollution Severity Level	3	2	2
Rated Voltage	250 V	320 V	630 V
Rated Impulse Voltage	4 kV	4 kV	4 kV
Rated Insulation Voltage	250 V acc. to EN 60998-1		
Rated Current	24 A		
Torque	0,4 Nm		

### Material

Moulding	PA HT, black, V-0
Comparative Tracking Index	CTI ≥ 600
Insulating Group	I
Temperature Range	-40°C up to 120°C; reflow solder temperature peak max. 255°C acc. to DIN EN 61760-1
Terminal body	Tin plated brass
Screw	M3; zink plated steel, clear passivated
Wire protector	Tin plated tin bronze

### Approvals

	Current [A]	Voltage [V]	Group	AWG	[Nm]
	20	300	B	18 - 12	0,4
	10	300	D	18 - 12	0,4
	20	300	B	18 - 12	0,4
	10	300	D	18 - 12	0,4

### Options / Accessories

- Consecutive numbering
- Special marking according to drawing
- Self-adhesive marking strip BST-5,00 [1]

### Part Numbers: Tape-on-Reel

No. of poles	974-D-SMD-DS	Tape Width	Tape Height	PU
2	20.874.402.A00	56 mm	14,7 mm	250
3	20.874.403.A00	56 mm	14,7 mm	250
4	20.874.404.A00	56 mm	14,7 mm	250
5	20.874.405.A00	56 mm	14,7 mm	250
6	20.874.406.A00	56 mm	14,7 mm	250

[1] To be fitted after reflow soldering process

## 210-A-111-THR

PCB connector for THR  
Screw connection

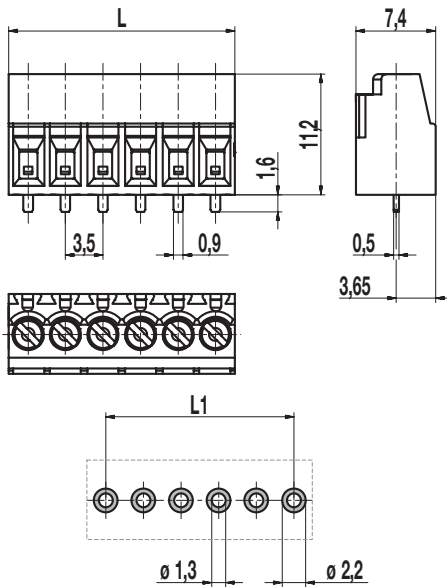

### Part Numbers

No. of poles	210-A-111-THR	Length	PU
2	10.804.102	7,00	250
3	10.804.103	10,50	250
4	10.804.104	14,00	250
5	10.804.105	17,50	200
6	10.804.106	21,00	200
7	10.804.107	24,50	100
8	10.804.108	28,00	100
9	10.804.109	31,50	100
10	10.804.110	35,00	100
11	10.804.111	38,50	100
12	10.804.112	42,00	100

further number of poles on request

### General Information

Pitch	3,5 mm
No. of poles	2 - 12

### Technical Data

Clamping Range	<i>solid / flexible / AWG</i> 0,14 - 1,5 mm <sup>2</sup> / 0,14 - 1,5 mm <sup>2</sup> / 30 - 16 AWG		
Rated Cross Section	1 mm <sup>2</sup>		
Wire Stripping Length	5,5 mm ± 0,5 mm		
Overvoltage Category	III	III	II
Pollution Severity Level	3	2	2
Rated Voltage	160 V	160 V	320 V
Rated Impulse Voltage	2,5 kV	2,5 kV	2,5 kV
Rated Insulation Voltage	130 V acc. to EN 60998-1		
Rated Current	12,5 A		
Soldering process	Reflow solder		
Hole in PCB	ø 1,3 mm		
PCB thickness	1,6 mm		
Torque	0,2 Nm		

### Material

Moulding	PA HT, black, V-0
Comparative Tracking Index	CTI ≥ 600
Insulating Group	I
Temperature Range	-40°C up to 120°C; reflow solder temperature peak max. 255°C acc. to DIN EN 61760-1
Terminal body	Nickel plated brass
Pressure clamp	Copper alloy, tin plated
Screw	M2; copper alloy, tin plated
Solder pin	Copper alloy, tin plated

### Options / Accessories

- Consecutive numbering
- Special marking accord. drawing
- Self-adhesive marking strip [1]
- Version with anti-twist-peg
- Tape-on-Reel on request
- White housing colour on request
- Other solder pin lengths on request

[1] To be fitted after reflow soldering process

## 930-THR(-DS)

PCB connector for THR  
Screw connection

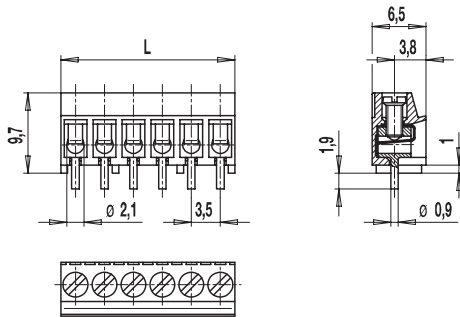

### PCB Layout

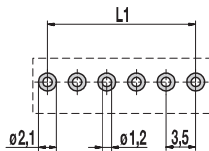

$L1 = (\text{No. of poles} - 1) \times \text{pitch}$   
Solder paste thickness: 0,15 - 0,2 mm  
Solder pad diameter: ø 2,1 mm

This product based on our established 930 series have been designed for the soldering process in Through-Hole-Reflow technology.

The soldering paste is applied to the plated through holes and the pins are placed in the circuit board and soldered by a reflow oven.

The terminal mouldings are made of heat-resistant material. The stand-offs on the base ensures there is enough room for the soldering paste and facilitates good heat circulation for optimum soldering and enables the soldering joint to be visually inspected.

The solder pin projects very slightly with a circuit board thickness of 1,6 mm and creates a solder point on both sides and thus guarantees a secure mounting. The position of the solder pins enables an equally minimal allocation area on the circuit board as with wave soldering.

### Part Numbers

No. of poles	930-THR	930-THR-DS	Length	PU
2	10.879.002	20.879.002	7,40	250
3	10.879.003	20.879.003	10,90	250
4	10.879.004	20.879.004	14,40	250
5	10.879.005	20.879.005	17,90	200
6	10.879.006	20.879.006	21,40	200
7	10.879.007	20.879.007	24,90	100
8	10.879.008	20.879.008	28,40	100
9	10.879.009	20.879.009	31,90	100
10	10.879.010	20.879.010	35,40	100
11	10.879.011	20.879.011	38,90	100
12	10.879.012	20.879.012	42,40	100
15	10.879.015	20.879.015	52,90	100

### General Information

Pitch	3,5 mm
No. of poles	2 - 12, 15



### Technical Data

Clamping Range	<i>solid / flexible / AWG</i>		
	<i>without wire protector</i>	0,75 - 1,5 mm <sup>2</sup> / 0,75 - 1,5 mm <sup>2</sup> / 18 - 16 AWG	
	<i>with wire protector</i>	0,34 - 1,5 mm <sup>2</sup> / 0,34 - 1 mm <sup>2</sup> / 22 - 16 AWG	
Rated Cross Section	1 mm <sup>2</sup>		
Wire Stripping Length	5 mm ± 0,5 mm		
Overvoltage Category	III	III	II
Pollution Severity Level	3	2	2
Rated Voltage	160 V	160 V	320 V
Rated Impulse Voltage	2,5 kV	2,5 kV	2,5 kV
Rated Insulation Voltage	130 V acc. to EN 60998-1		
Rated Current	13,5 A		
Soldering process	Wave solder & reflow solder		
Hole in PCB	ø 1,2 mm		
PCB thickness	Wave solder max. 1,6 mm; reflow solder 0,8-1,6 mm		
Torque	0,2 Nm		

### Material

Moulding	PA HT, black, V-0
Comparative Tracking Index	CTI ≥ 600
Insulating Group	I
Temperature Range	-40°C up to 120°C; reflow solder temperature peak max. 255°C acc. to DIN EN 61760-1
Terminal body	Tin plated brass
Screw	M2; zinc plated steel, blue passivated
Solder pin	ø 0,9 mm; tin plated brass
Wire protector	German silver

### Approvals

	Current [A]	Voltage [V]	Group	AWG	[Nm]
	10	300	B	26 - 16	0,23
	10	300	B	26 - 16	0,2

### Options / Accessories

- Special marking according to drawing
- Self-adhesive marking strip BST-3,50 [1]
- Other solder pin lengths on request
- Large conductor space with terminal body 938 on request

### Part Numbers: Tape-on-Reel

No. of poles	930-THR	930-THR-DS	Tape Width	Tape Height	PU
3		20.879.003.A00	32 mm	13 mm	500
6		20.879.006.A00	56 mm	13 mm	500
12		20.879.012.A00	56 mm	13 mm	500

further number of poles on request

[1] To be fitted after reflow soldering process

## 934-THR-DS

PCB connector for THR  
Screw connection 45°-angle to PCB

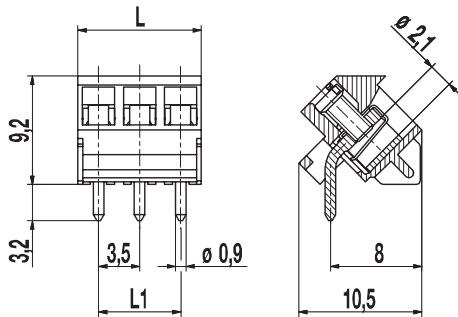

### PCB Layout

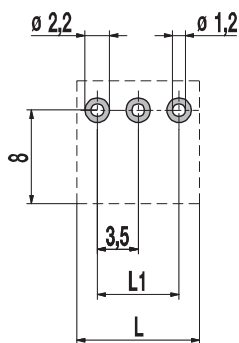

L1 = (No. of poles - 1) x pitch  
Solder paste thickness: 0,15 - 0,2 mm  
Solder pad diameter:  $\varnothing$  2,2 mm

934-THR-DS is a PCB connector for the reflow soldering process with a pitch of 3,5 mm. It is available in 2- to 12-pole design.

The wire entry has a connection angle of 45° to the PCB. This offers the advantage that terminal rows can be located space saving one directly behind the other. Additionally, the connectors can be arranged side by side without a change of the pitch.

The housing material consists of high temperature resistant plastic. Spacers, so-called "Stand-offs" on the base assure an improved hot-air circulation during the reflow soldering process in the convection oven.

The PCB connector 934-THR-DS is standardly equipped with captive screws and wire protectors.

This connector is packed Tape-on-Reel for the automatic assembling. It has a flat roof design on the housing at the middle poles in order to create a flat surface for the vacuum pipette.

### Part Numbers

No. of poles	934-THR-DS	Length	PU
2	20.879.302	7,00	250
4	20.879.304	14,00	250
6	20.879.306	21,00	200
12	20.879.312	42,00	100

further number of poles on request

### General Information

Pitch	3,5 mm
No. of poles	2 - 12
Areas of application	Devices with space critical applications or multi-row connections

### Technical Data

Clamping Range	<i>solid / flexible / AWG</i>		
	0,25 - 1,5 mm <sup>2</sup> / 0,25 - 1 mm <sup>2</sup> / 24 - 16 AWG		
Rated Cross Section	1 mm <sup>2</sup>		
Wire Stripping Length	5 mm $\pm$ 0,5 mm		
Overvoltage Category	III	III	II
Pollution Severity Level	3	2	2
Rated Voltage	160 V	160 V	320 V
Rated Impulse Voltage	2,5 kV	2,5 kV	2,5 kV
Rated Insulation Voltage	130 V acc. to EN 60998-1		
Rated Current	10 A		
Soldering process	Wave solder & reflow solder		
Hole in PCB	$\varnothing$ 1,2 mm		
PCB thickness	Wave solder max. 1,6 mm; reflow solder 1,6 mm - 3,2 mm		
Torque	0,2 Nm		

### Material

Moulding	PA HT, black, V-0
Comparative Tracking Index	CTI $\geq$ 600
Insulating Group	I
Temperature Range	-40°C up to 120°C; reflow solder temperature peak max. 255°C acc. to DIN EN 61760-1
Terminal body	Tin plated brass
Screw	M2; zinc plated steel, blue passivated
Solder pin	$\varnothing$ 0,9 mm; tin plated brass
Wire protector	German silver

### Approvals

	Current [A]	Voltage [V]	Group	AWG	[Nm]
	10	300	B	26 - 16	0,23
	10	300	B	26 - 16	0,2

### Options / Accessories

- Consecutive numbering
- Special marking according to drawing
- Self-adhesive marking strip BST-3,50 [1]
- Other plug pin lengths on request

### Part Numbers: Tape-on-Reel

No. of poles	934-THR-DS	Tape Width	Tape Height	PU
2	20.879.302.A00	32 mm	15,2 mm	300
5	20.879.305.A00	32 mm	15,2 mm	300

further number of poles on request

[1] To be fitted after reflow soldering process

# 140-A-111-THR

PCB connector for THR  
Screw connection, short solder pins

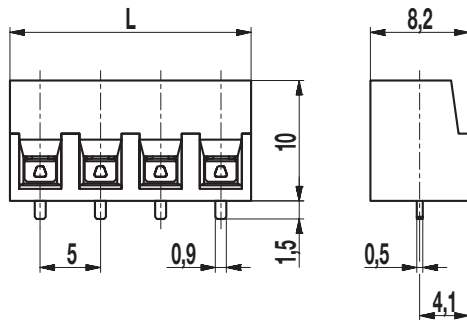

### Recommended PCB Layout

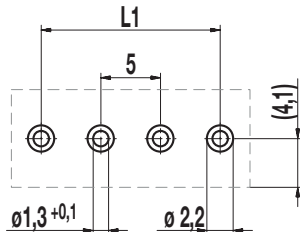

L1 = (No. of poles - 1) x pitch  
Solder pad diameter:  $\varnothing$  2,2 mm  
Solder paste thickness: 0,15 - 0,2 mm

The PCB connector 140-A-111-THR with a pitch of 5 mm, designed for the soldering process in Through-Hole-Reflow technology, is available in 2- to 12-pole design.

The very short 1.5 mm solder pins, no longer protruding from the PC board, allow for double-sided mounting possibilities.

The terminal housing is made of heat-resistant material.  
The wire entrance is parallel to the PCB.  
The screws are captive.

### Part Numbers

No. of poles	140-A-111-THR	Length	PU
2	10.801.562	10,00	250
3	10.801.563	15,00	250
4	10.801.564	20,00	200
5	10.801.565	25,00	100
6	10.801.566	30,00	100

further number of poles on request

### General Information

Pitch	5 mm
No. of poles	2 - 12

### Technical Data

Clamping Range	solid / flexible / AWG		
	0,14 - 2,5 mm <sup>2</sup> / 0,14 - 1,5 mm <sup>2</sup> / 26 - 16 AWG		
Rated Cross Section	1,5 mm <sup>2</sup>		
Wire Stripping Length	6 mm $\pm$ 0,5 mm		
Overvoltage Category	III	III	II
Pollution Severity Level	3	2	2
Rated Voltage	200 V	320 V	500 V
Rated Impulse Voltage	4 kV	4 kV	4 kV
Rated Insulation Voltage	250 V accord. to EN 60998-1		
Rated Current	16 A		
Soldering process	Reflow solder		
Hole in PCB	$\varnothing$ 1,3 mm		
PCB thickness	1,6 mm		
Torque	0,5 Nm		

### Material

Moulding	PA HT, black, V-0
Comparative Tracking Index	CTI $\geq$ 600
Insulating Group	I
Temperature Range	-40°C up to 120°C; reflow solder temperature peak max. 255°C acc. to DIN EN 61760-1
Terminal body	Nickel plated brass
Pressure clamp	Tin plated copper alloy
Screw	M3; Zinc plated steel, blue passivated
Solder pin	0,9 x 0,5 mm; tin plated copper alloy

### Options / Accessories

- Consecutive numbering
- Special marking according to drawing
- Self-adhesive marking strip BST-5,00 [1]
- Pitch of 10 mm for larger clearance and creepage distances
- Tape-on-Reel on request
- Other solder pin lengths on request

[1] To be fitted after reflow soldering process

## 950-THR(-DS)

PCB connector for THR  
Screw connection

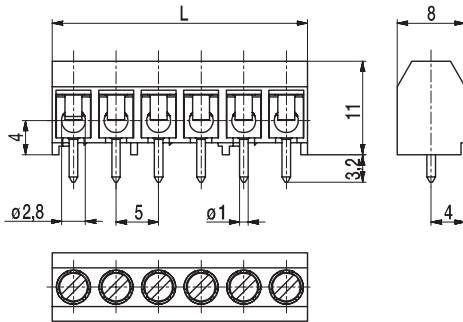
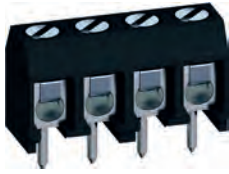

### PCB Layout

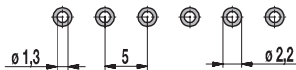

Solder paste thickness: 0,15 - 0,2 mm  
Solder pad diameter:  $\varnothing$  2,2 mm

The PCB connector 950-THR with a pitch of 5 mm, designed for the soldering process in Through-Hole-Reflow technology, is available in 2- to 12-pole design. The terminal housing is made of heat-resistant material. The stand-offs on the base ensures there is enough room for the soldering paste and facilitates good heat circulation for optimum soldering and enables the soldering joint to be visually inspected.

The solder pin projects very slightly with a circuit board thickness of 1,6 mm and creates a solder point on both sides and thus guarantees a secure mounting. The position of the solder pins enables an equally minimal allocation area on the circuit board as with wave soldering.

This connector is also available with enlarged clamping size (958-THR).

### Part Numbers

No. of poles	950-THR	950-THR-DS	Length	PU
2	10.879.102	20.879.102	10,00	250
3	10.879.103	20.879.103	15,00	250
4	10.879.104	20.879.104	20,00	100
5	10.879.105	20.879.105	25,00	100
6	10.879.106	20.879.106	30,00	100
7	10.879.107	20.879.107	35,00	100
8	10.879.108	20.879.108	40,00	100
9	10.879.109	20.879.109	45,00	100
10	10.879.110	20.879.110	50,00	100
11	10.879.111	20.879.111	55,00	100
12	10.879.112	20.879.112	60,00	100

### General Information

Pitch	5 mm
No. of poles	2 - 12



### Technical Data

Clamping Range	<i>solid / flexible / AWG</i>		
<i>without wire protector</i>	0,75 - 4 mm <sup>2</sup> / 0,75 - 2,5 mm <sup>2</sup> / 18 - 12 AWG		
<i>with wire protector</i>	0,34 - 2,5 mm <sup>2</sup> / 0,34 - 2,5 mm <sup>2</sup> / 22 - 14 AWG		
Rated Cross Section	1,5 mm <sup>2</sup>		
Wire Stripping Length	6 mm $\pm$ 0,5 mm		
Overvoltage Category	III	III	II
Pollution Severity Level	3	2	2
Rated Voltage	160 V	160 V	320 V
Rated Impulse Voltage	2,5 kV	2,5 kV	2,5 kV
Rated Insulation Voltage	250 V acc. to EN 60998-1		
Rated Current	17,5 A		
Soldering process	Wave solder & reflow solder		
Hole in PCB	$\varnothing$ 1,3 mm		
PCB thickness	Wave solder max. 1,6 mm; reflow solder 1,6 - 3,2 mm		
Torque	0,4 Nm		

### Material

Moulding	PA HT, black, V-0
Comparative Tracking Index	CTI $\geq$ 600
Insulating Group	I
Temperature Range	-40°C up to 120°C; reflow solder temperature peak max. 255°C acc. to DIN EN 61760-1
Terminal body	Tin plated brass
Screw	M2,6; zinc plated steel, blue passivated
Solder pin	$\varnothing$ 1 mm; tin plated brass
Wire protector	Tin plated tin bronze

### Approvals

	Current [A]	Voltage [V]	Group	AWG	[Nm]
	15	300	B	26 - 14	0,4
	15	300	B	26 - 14	0,4

### Options / Accessories

- Consecutive numbering
- Special marking according to drawing
- Self-adhesive marking strip BST-5,00 [1]
- Other solder pin lengths on request

### Part Numbers: Tape-on-Reel

No. of poles	950-THR	950-THR-DS	Tape Width	Tape Height	PU
2		20.879.102.A00	32 mm	15,7 mm	300
6		20.879.106.A00	56 mm	15,7 mm	300

further number of poles on request

[1] To be fitted after reflow soldering process

# 970-THR(-DS)

PCB connector for THR  
Screw connection

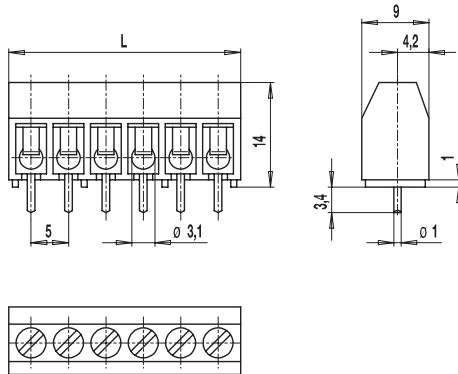

## PCB Layout

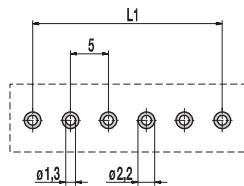

$L1 = (\text{No. of poles} - 1) \times \text{pitch}$   
Solder paste thickness: 0,15 - 0,2 mm  
Solder pad diameter:  $\varnothing$  2,2 mm

The PCB connector 970-THR with a pitch of 5 mm is available in 2- to 12-pole design. It has been designed for the soldering process in Through-Hole-Reflow technology. The soldering paste is applied to the plated through holes and the pins are placed in the circuit board and soldered by a reflow oven. The terminal mouldings are made of heat-resistant material. The stand-offs on the base ensures there is enough room for the soldering paste and facilitates good heat circulation for optimum soldering and enables the soldering joint to be visually inspected. The solder pin projects very slightly with a circuit board thickness of 1,6 mm and creates a solder point on both sides and thus guarantees a secure mounting. The position of the solder pins enables an equally minimal allocation area on the circuit board as with wave soldering. This connector is also available with enlarged clamping size.

## Part Numbers

No. of poles	970-THR	970-THR-DS	Length	PU
2	10.879.202	20.879.202	11,00	250
3	10.879.203	20.879.203	16,00	250
4	10.879.204	20.879.204	21,00	200
5	10.879.205	20.879.205	26,00	100
6	10.879.206	20.879.206	31,00	100
8	10.879.208	20.879.208	41,00	100
10	10.879.210	20.879.210	51,00	100
12	10.879.212	20.879.212	61,00	100

further number of poles on request

## General Information

Pitch	5 mm
No. of poles	2 - 12

## Technical Data

Clamping Range	<i>solid / flexible / AWG</i>		
	<i>without wire protector</i>	1 - 6 mm <sup>2</sup> / 1 - 2,5 mm <sup>2</sup> / 16 - 12 AWG	
	<i>with wire protector</i>	0,75 - 4 mm <sup>2</sup> / 0,75 - 2,5 mm <sup>2</sup> / 18 - 12 AWG	
Rated Cross Section	2,5 mm <sup>2</sup>		
Wire Stripping Length	6,5 mm $\pm$ 0,5 mm		
Overvoltage Category	III	III	II
Pollution Severity Level	3	2	2
Rated Voltage	250 V	320 V	630 V
Rated Impulse Voltage	4 kV	4 kV	4 kV
Rated Insulation Voltage	250 V acc. to EN 60998-1		
Rated Current	24 A		
Soldering process	Wave solder & reflow solder		
Hole in PCB	$\varnothing$ 1,3 mm		
PCB thickness	Wave solder max. 1,6 mm; reflow solder 1,6 - 3,2 mm		
Torque	0,5 Nm		

## Material

Moulding	PA HT, black, V-0
Comparative Tracking Index	CTI $\geq$ 600
Insulating Group	I
Temperature Range	-40°C up to 120°C; reflow solder temperature (Peak) max. 260°C (15-30 s)
Terminal body	Tin plated brass
Screw	M3; zinc plated steel, blue passivated
Solder pin	$\varnothing$ 1 mm; tin plated copper
Wire protector	Tin plated tin bronze

## Approvals

	Current [A]	Voltage [V]	Group	AWG	[Nm]
	20	300	B	22-12 [1]	0,51
	10	300	D	22-12 [1]	0,51
	20	300	B	26 - 12	0,51
	10	300	D, E	26 - 12	0,51

## Options / Accessories

- Consecutive numbering / Special marking according to drawing
- Self-adhesive marking strip BST-5,00 [2]
- Other solder pin lengths on request

## Part Numbers: Tape-on-Reel

No. of poles	970-THR	970-THR-DS	Tape Width	Tape Height	PU
2		20.879.202.A00	32 mm	18,8 mm	225
4		20.879.204.A00	32 mm	18,8 mm	225

further number of poles on request

- [1] No. 26 AWG min for factory-wiring only  
[2] To be fitted after reflow soldering process

# Pin strips

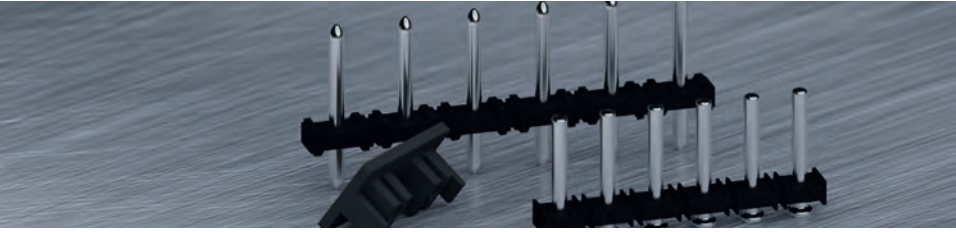

## SMD

Pitch 3.5 mm	 931-SLR-SMD-1,1 <b>34</b>	 931-SLR-SMD-1,3 <b>35</b>
	 971-SLR-SMD-1,1 <b>36</b>	 971-SLR-SMD-1,3 <b>37</b>

## THR

Pitch 3.5 mm	 931-SLR-THR <b>39</b>	 931-SLR-THR-1,1 <b>40</b>	 931-SLR-THR-1,3 <b>41</b>
	 971-SLR-THR <b>42</b>	 971-SLR-THR-1,1 <b>43</b>	 971-SLR-THR-1,3 <b>44</b>

Pin strips



## 931-SLR-SMD-1,1

Pin strip for SMD  
Plug-in area  $\varnothing$  1,1 mm

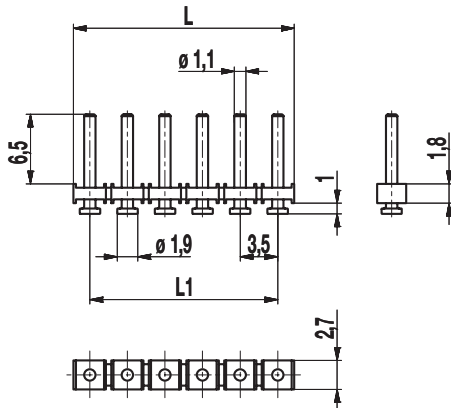

$L1 = (\text{No. of poles} - 1) \times \text{pitch}$

### PCB Layout

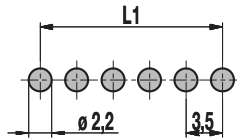

Solder paste thickness: 0,15 - 0,2 mm

The pin strip 931-SLR-SMD-1,1 for the application in a reflow soldering process in genuine SMD technology and with a pitch of 3,5 mm is available in 2 to 16 pole design.

It comes with a constant pin diameter of 1,1 mm at the plug-in area.

Contrary to the pin strips 931-SLR-THR and 931-SLR-THR-1,1, for which holes in the PCB are necessary, the SMD types of WECO base on true surface assembly. Soldering expands at the end of the pins guarantee optimal retention force on the printed circuit board.

Just like all THR versions of WECO, also the housings of the SMD series are made out of high temperature resistant plastic material and exhibit a very high CTI value. For the automatic assembling all pin strips of this series are packed in Tape-on-Reel and equipped with high temperature resistant Pick Caps, which can easily be removed after the soldering process.

### Part Numbers

No. of poles	931-SLR-SMD-1,1	Length	PU
2	12.893.732	6,50	1000
3	13.893.732	10,00	1000
4	14.893.732	13,50	500
5	15.893.732	17,00	500
6	16.893.732	20,50	500
8	18.893.732	27,50	250
10	20.893.732	34,50	200
12	22.893.732	41,50	200
16	26.893.732	55,50	200

further number of poles on request

### General Information

Pitch	3,5 mm
No. of poles	2 - 16
Usable with	plug connector 930-FL(-DS)
Additional Information	Also, please take into consideration the pin strips 931-SLS for wave soldering and series 931-SLR-THR for Through-Hole-Reflow.



### Technical Data

Overvoltage Category	III	III	II
Pollution Severity Level	3	2	2
Rated Voltage	160 V	160 V	320 V
Rated Impulse Voltage	2,5 kV	2,5 kV	2,5 kV
Rated Insulation Voltage	130 V acc. to EN 60998-1		
Rated Current	6 A		
Soldering process	Reflow solder		

### Material

Moulding	PA HT, black, V-0
Comparative Tracking Index	CTI $\geq$ 600
Insulating Group	I
Temperature Range	-40°C up to 120°C; reflow solder temperature peak max. 255°C acc. to DIN EN 61760-1
Solder pin	$\varnothing$ 1,1 mm (plug-in area); tin plated brass

### Approvals

	Current [A]	Voltage [V]	Group	AWG	[Nm]
	6	150	B		
	6	300	D		
	6	150	B		
	6	300	D		

### Options / Accessories

- Other plug pin lengths on request
- Other solder pin surfaces on request

### Part Numbers: Tape-on-Reel

No. of poles	931-SLR-SMD-1,1	Tape Width	Tape Height	PU
2	12.893.732.A00	24 mm	14,8 mm	500
3	13.893.732.A00	32 mm	14,6 mm	500
4	14.893.732.A00	32 mm	14,6 mm	500
5	15.893.732.A00	32 mm	14,6 mm	500
6	16.893.732.A00	56 mm	14,6 mm	500
7	17.893.732.A00	56 mm	14,6 mm	500
8	18.893.732.A00	56 mm	14,6 mm	500
9	19.893.732.A00	56 mm	14,6 mm	500
10	20.893.732.A00	56 mm	14,6 mm	500
11	21.893.732.A00	56 mm	14,6 mm	500
12	22.893.732.A00	72 mm	14,9 mm	500
13	23.893.732.A00	72 mm	14,9 mm	500
14	24.893.732.A00	72 mm	14,9 mm	500

further number of poles on request

## 931-SLR-SMD-1,3

Pin strip for SMD  
Plug-in area  $\varnothing$  1,3 mm

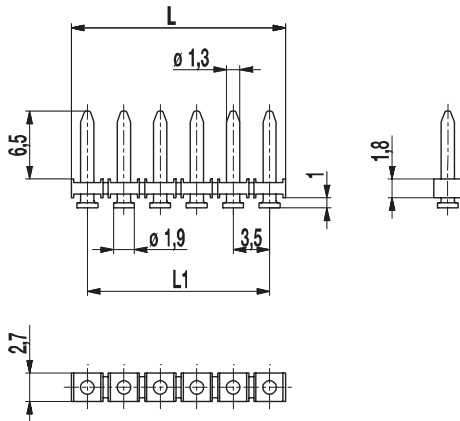

$$L1 = (\text{No. of poles} - 1) \times \text{pitch}$$

### PCB Layout

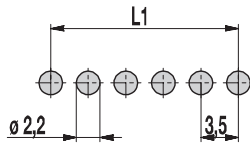

Solder paste thickness: 0,15 - 0,2 mm

The pin strip 931-SLR-SMD-1,3 for the application in a reflow soldering process in genuine SMD technology and with a pitch of 3,5 mm is available in 2 to 16 pole design.

It comes with a constant pin diameter of 1,3 mm at the plug-in area. Contrary to the pin strips 931-SLR-THR and 931-SLR-THR-1,3, for which holes in the PCB are necessary, the SMD types of WECO base on true surface assembly. Soldering expanses at the end of the pins guarantee optimal retention force on the printed circuit board.

Just like all THR versions of WECO, also the housings of the SMD series are made out of high temperature resistant plastic material and exhibit a very high CTI value. For the automatic assembling all pin strips of this series are packed in Tape-on-Reel and equipped with high temperature resistant Pick Caps, which can easily be removed after the soldering process.

### Part Numbers

No. of poles	931-SLR-SMD-1,3	Length	PU
2	12.893.731	6,50	1000
3	13.893.731	10,00	1000
4	14.893.731	13,50	500
6	16.893.731	20,50	500
8	18.893.731	27,50	250
10	20.893.731	34,50	200
12	22.893.731	41,50	200
16	26.893.731	55,50	200

further number of poles on request

### General Information

Pitch	3,5 mm
No. of poles	2 - 16
Usable with	plug connector 938-FLDS
Additional Information	Also, please take into consideration the pin strips 931-SLS for wave soldering and series 931-SLR-THR for Through-Hole-Reflow.



### Technical Data

Overvoltage Category	III	III	II
Pollution Severity Level	3	2	2
Rated Voltage	160 V	160 V	320 V
Rated Impulse Voltage	2,5 kV	2,5 kV	2,5 kV
Rated Insulation Voltage	130 V acc. to EN 60998-1		
Rated Current	6 A		
Soldering process	Reflow solder		

### Material

Moulding	PA HT, black, V-0
Comparative Tracking Index	CTI $\geq$ 600
Insulating Group	I
Temperature Range	-40°C up to 120°C; reflow solder temperature peak max. 255°C acc. to DIN EN 61760-1
Solder pin	$\varnothing$ 1,3 mm (plug-in area); tin plated brass

### Approvals

	Current [A]	Voltage [V]	Group	AWG	[Nm]
	6	150	B		
	6	300	D		
	6	150	B		
	6	300	D		

### Options / Accessories

- Plug pin length 11,3 mm with mating area 8,5 mm (instead of 6.5 mm) available
- Other plug pin lengths on request
- Other solder pin surfaces on request

### Part Numbers: Tape-on-Reel

No. of poles	931-SLR-SMD-1,3	Tape Width	Tape Height	PU
2	12.893.731.A00	24 mm	14,8 mm	500
3	13.893.731.A00	32 mm	14,6 mm	500
4	14.893.731.A00	32 mm	14,6 mm	500
5	15.893.731.A00	32 mm	14,6 mm	500
6	16.893.731.A00	56 mm	14,6 mm	500
7	17.893.731.A00	56 mm	14,6 mm	500
8	18.893.731.A00	56 mm	14,6 mm	500
9	19.893.731.A00	56 mm	14,6 mm	500
10	20.893.731.A00	56 mm	14,6 mm	500
11	21.893.731.A00	56 mm	14,6 mm	500
12	22.893.731.A00	72 mm	14,9 mm	500
13	23.893.731.A00	72 mm	14,9 mm	500
14	24.893.731.A00	72 mm	14,9 mm	500

further number of poles on request

# 971-SLR-SMD-1,1

Pin strip for SMD  
Plug-in area  $\varnothing$  1,1 mm

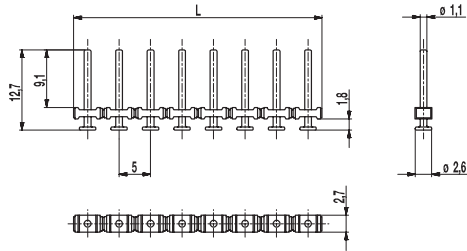

## PCB Layout

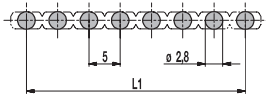

$L1 = (\text{No. of poles} - 1) \times \text{pitch}$   
Solder paste thickness: 0,15 - 0,2 mm

971-SLR-SMD is a pin strip with a pitch of 5 mm for the application in a reflow soldering process.

In contrary to the well-known pin rows 971-SLR and 971-SLR-THR, for which holes in the PCB are necessary, the SMD types of WECO base on true surface assembly.

Soldering expanses at the end of the pins guarantee optimal retention force on the printed circuit board.

We recommend this pin strip with a diameter of 1,1 in the mating area for higher numbers of poles, in order to minimize the plug-in and withdrawal forces here.

Just like all THR versions of WECO also the housings of the SMD series are made out of high temperature resistant plastic material and exhibit a very high CTI value. For the automatic assembling all pin strips of this series are packed in Tape-on-Reel and equipped with high temperature resistant Pick Caps, which can easily be removed after the soldering process.

## Part Numbers

No. of poles	971-SLR-SMD-1,1	Length	PU
2	12.893.822	9,50	1000
3	13.893.822	14,50	500
4	14.893.822	19,50	500
5	15.893.822	24,50	250
6	16.893.822	29,50	250
10	20.893.822	49,50	100
12	22.893.822	59,50	100

further number of poles on request

## General Information

Pitch	5 mm
No. of poles	2 - 12
Usable with	plug connectors of series 115-F-.../..-1,-1-SW; 950-FL-DS, 950-TFL-DS, 950-NAF-DS, 950-GFL-DS, 950-NLFL-DS, 950-RFL-DS

## Technical Data

Overvoltage Category	III	III	II
Pollution Severity Level	3	2	2
Rated Voltage	160 V	160 V	320 V
Rated Impulse Voltage	2,5 kV	2,5 kV	2,5 kV
Rated Insulation Voltage	130 V acc. to EN 60998-1		
Rated Current	10 A		
Soldering process	Reflow solder		

## Material

Moulding	PA HT, black, V-0
Comparative Tracking Index	CTI $\geq$ 600
Insulating Group	I
Temperature Range	-40°C up to 120°C; reflow solder temperature peak max. 255°C acc. to DIN EN 61760-1
Solder pin	$\varnothing$ 1,1 mm (plug-in area); tin plated brass

## Approvals

	Current [A]	Voltage [V]	Group	AWG	[Nm]
	10 [1]	300	B		
	10	300	B		

[1] Above headers with 1.0 or 1.1 mm dia. pins are rated 12A max. with manufacturer's Cat. No. 120-W-111 terminal blocks. Above headers with 1.1 mm or 1.3 mm dia. pins are rated 12A max. with 115-F-111, 115-F-211 and 115-F-118 terminal blocks.

## Options / Accessories

- Other plug pin lengths on request
- Other solder pin surfaces on request

## Part Numbers: Tape-on-Reel

No. of poles	971-SLR-SMD-1,1	Tape Width	Tape Height	PU
2	12.893.822.A00	32 mm	15,9 mm	500
3	13.893.822.A00	32 mm	15,9 mm	500
4	14.893.822.A00	56 mm	15,9 mm	500
5	15.893.822.A00	56 mm	15,9 mm	500
6	16.893.822.A00	56 mm	15,9 mm	500
7	17.893.822.A00	56 mm	15,9 mm	500
8	18.893.822.A00	72 mm	14,9 mm	500
9	19.893.822.A00	72 mm	14,9 mm	500
10	20.893.822.A00	72 mm	14,9 mm	500
11	21.893.822.A00	88 mm	15,8 mm	500
12	22.893.822.A00	88 mm	15,8 mm	500

further number of poles on request

# 971-SLR-SMD-1,3

Pin strip for SMD  
Plug-in area  $\varnothing$  1,3 mm

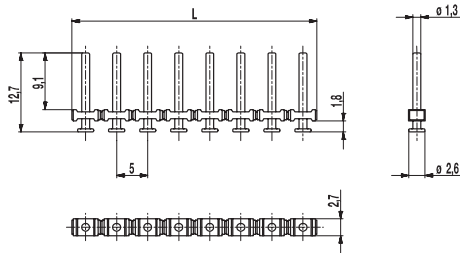

## PCB Layout

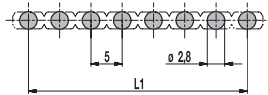

$L1 = (\text{No. of poles} - 1) \times \text{pitch}$   
Solder paste thickness: 0,15 - 0,2 mm

971-SLR-SMD is a pin strip with a pitch of 5 mm for the application in a reflow soldering process. In contrary to the well-known pin rows 971-SLR and 971-SLR-THR, for which holes in the PCB are necessary, the SMD types of WECO base on true surface assembly. Soldering expands at the end of the pins guarantee optimal retention force on the printed circuit board.

The pin strip 971-SLR-SMD-1,3 with the pin diameter of 1,3 mm at the plug-in area, is rather suitable for the small numbers of poles of the plug connector (see general information). The obtained plug-in and pull-out forces are comfortable.

Just like all THR versions of WECO also the housings of the SMD series are made out of high temperature resistant plastic material and exhibit a very high CTI value. For the automatic assembling all pin strips of this series are packed in Tape-on-Reel and equipped with high temperature resistant Pick Caps, which can easily be removed after the soldering process.

## Part Numbers

No. of poles	971-SLR-SMD-1,3	Length	PU
2	12.893.821	9,50	1000
3	13.893.821	14,50	500
4	14.893.821	19,50	500
5	15.893.821	24,50	250
6	16.893.821	29,50	250
10	20.893.821	49,50	100
12	22.893.821	59,50	100

further number of poles on request

## General Information

Pitch	5 mm
No. of poles	2 - 12
Usable with	plug connectors of series 115-F, 950-FL-DS, 950-TFL-DS, 950-NAF-DS, 950-GFL-DS, 950-NLFL-DS, 950-RFL-DS

## Technical Data

Overvoltage Category	III	III	II
Pollution Severity Level	3	2	2
Rated Voltage	160 V	160 V	320 V
Rated Impulse Voltage	2,5 kV	2,5 kV	2,5 kV
Rated Insulation Voltage	130 V acc. to EN 60998-1		
Rated Current	10 A		
Soldering process	Reflow solder		

## Material

Moulding	PA HT, black, V-0
Comparative Tracking Index	CTI $\geq$ 600
Insulating Group	I
Temperature Range	-40°C up to 120°C; reflow solder temperature peak max. 255°C acc. to DIN EN 61760-1
Solder pin	$\varnothing$ 1,3 mm (plug-in area); tin plated brass

## Approvals

	Current [A]	Voltage [V]	Group	AWG	[Nm]
	10 [1]	300	B		
	10	300	B		

[1] Above headers with 1.0 or 1.1 mm dia. pins are rated 12A max. with manufacturer's Cat. No. 120-W-111 terminal blocks. Above headers with 1.1 mm or 1.3 mm dia. pins are rated 12A max. with 115-F-111, 115-F-211 and 115-F-118 terminal blocks.

## Options / Accessories

- Other plug pin lengths on request
- Other solder pin surfaces on request

## Part Numbers: Tape-on-Reel

No. of poles	971-SLR-SMD-1,3	Tape Width	Tape Height	PU
2	12.893.821.A00	32 mm	15,9 mm	500
3	13.893.821.A00	32 mm	15,9 mm	500
4	14.893.821.A00	56 mm	15,9 mm	500
5	15.893.821.A00	56 mm	15,9 mm	500
6	16.893.821.A00	56 mm	15,9 mm	500
7	17.893.821.A00	56 mm	15,9 mm	500
8	18.893.821.A00	72 mm	14,9 mm	500
9	19.893.821.A00	72 mm	14,9 mm	500
10	20.893.821.A00	72 mm	14,9 mm	500

further number of poles on request

## 971-SLT-SMD

Pin strip for SMD  
Low profile

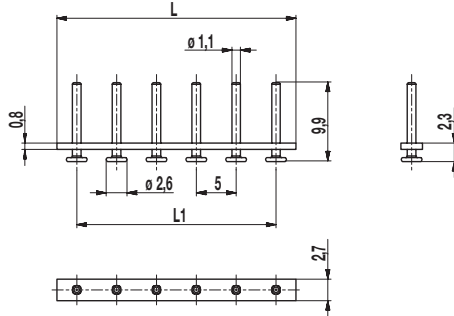

### PCB Layout

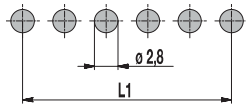

$L1 = (\text{No. of poles} - 1) \times \text{pitch}$   
Solder paste thickness: 0,15 - 0,2 mm

971-SLT-SMD is a pin strip with a pitch of 5 mm for the application in a reflow soldering process with low profile for space critical applications. Contrary to the well-known pin strips of 971-SLR and 971-SLR-THR, for which holes in the PCB are necessary, the SMD types of WECO base on true surface assembly.

Soldering expands at the end of the pins guarantee optimal retention force on the printed circuit board.

We recommend this pin strip with pin diameter of 1,1 mm in the mating area for higher numbers of poles, in order to minimize the plug-in and withdrawal forces here.

Just like all THR versions of WECO, also the housings of the SMD series are made out of high temperature resistant plastic material.

For the automatic assembling all pin strips of this series are packed in Tape-on-Reel and equipped with high temperature resistant Pick Caps, which can easily be removed after the soldering process.

### Part Numbers

No. of poles	971-SLT-SMD	Length	PU
2	12.893.656	10,00	1000
3	13.893.656	15,00	500
4	14.893.656	20,00	500
5	15.893.656	25,00	250
6	16.893.656	30,00	250
10	20.893.656	50,00	100

further number of poles on request

### General Information

Pitch	5 mm
No. of poles	2 - 12
Usable with	plug connectors of series 115-F-.../..-1,1-SW; 950-FL-DS, 950-TFL-DS, 950-NAF-DS, 950-GFL-DS, 950-NLFL-DS, 950-RFL-DS
Additional Information	Also, please take into consideration the pin strips 971-SLR for wave soldering and 971-SLR-THR for Through-Hole-Reflow.

### Technical Data

Overvoltage Category	III	III	II
Pollution Severity Level	3	2	2
Rated Voltage	160 V	160 V	250 V
Rated Impulse Voltage	2,5 kV	2,5 kV	2,5 kV
Rated Insulation Voltage	130 V acc. to EN 60998-1		
Rated Current	10 A		
Soldering process	Reflow solder		

### Material

Moulding	PA HT, black, V-0
Comparative Tracking Index	CTI $\geq$ 600
Insulating Group	I
Temperature Range	-40°C up to 120°C; reflow solder temperature (Peak) max. 255°C acc. to DIN EN 61760-1
Solder pin	$\varnothing$ 1,1 mm (plug-in area); tin plated brass

### Approvals

	Current [A]	Voltage [V]	Group	AWG	[Nm]
	10 [1]	300	B		
	10	300	B		

[1] Above headers with 1.0 or 1.1 mm dia. pins are rated 12A max. with manufacturer's Cat. No. 120-W-111 terminal blocks. Above headers with 1.1 mm or 1.3 mm dia. pins are rated 12A max. with 115-F-111, 115-F-211 and 115-F-118 terminal blocks.

### Options / Accessories

- Other plug pin lengths on request
- Other solder pin surfaces on request

### Part Numbers: Tape-on-Reel

No. of poles	971-SLT-SMD	Tape Width	Tape Height	PU
2	12.893.656.A00	32 mm	14,6 mm	500
4	14.893.656.A00	44 mm	15,0 mm	500
6	16.893.656.A00	44 mm	15,0 mm	500
10	20.893.656.A00	72 mm	14,9 mm	500

further number of poles on request

## 931-SLR-THR

Pin strip for THR

Soldering area  $\varnothing$  1 mm; plug-in area  $\varnothing$  1,3 mm

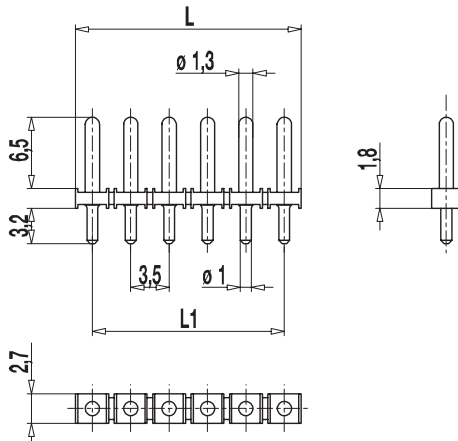

$$L1 = (\text{No. of poles} - 1) \times \text{pitch}$$

### PCB Layout

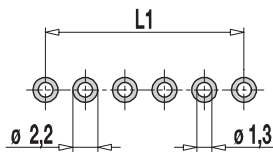

Solder paste thickness: 0,15 - 0,2 mm  
Solder pad diameter:  $\varnothing$  2,2 mm

931-SLR-THR is a pin strip with a pitch of 3,5 mm for the application in a reflow soldering process. The high temperature resistant plastic housing has a very high CTI value and is equipped with spacers, so-called stand-offs, which ensure a better hot-air circulation during the reflow soldering process in the convection oven. Beyond this, they assure an improved optical control of the solder joints. The pin strips of the series 931-SLR-THR comes with a stepped pin,  $\varnothing$  1,3 mm in the plug-in area and  $\varnothing$  1 mm in the soldering area.

For the automatic assembling all pin strips of this series are packed in Tape-on-Reel and equipped with high temperature resistant Pick Caps, which can easily be removed after the soldering process.

### Part Numbers

No. of poles	931-SLR-THR	Length	PU
2	12.893.721	6,50	1000
3	13.893.721	10,00	1000
4	14.893.721	13,50	500
5	15.893.721	17,00	500
6	16.893.721	20,50	500
8	18.893.721	27,50	250
10	20.893.721	34,50	200
12	22.893.721	41,50	200
16	26.893.721	55,50	200

further number of poles on request

### General Information

Pitch	3,5 mm
No. of poles	2 - 16
Usable with	plug connector 938-FLDS
Additional Information	Also, please take into consideration the pin strips 931-SLR-SMD-1,3 in genuine surface mount technology.

### Technical Data

Overvoltage Category	III	III	II
Pollution Severity Level	3	2	2
Rated Voltage	160 V	160 V	320 V
Rated Impulse Voltage	2,5 kV	2,5 kV	2,5 kV
Rated Insulation Voltage	130 V acc. to EN 60998-1		
Rated Current	6 A		
Soldering process	Wave solder & reflow solder		
Hole in PCB	$\varnothing$ 1,3 mm		
PCB thickness	Wave solder max. 1,6 mm; reflow solder 1,6 - 3,2 mm		

### Material

Moulding	PA HT, black, V-0
Comparative Tracking Index	CTI $\geq$ 600
Insulating Group	I
Temperature Range	-40°C up to 120°C; reflow solder temperature peak max. 255°C acc. to DIN EN 61760-1
Solder pin	$\varnothing$ 1,3 mm (plug-in area) / $\varnothing$ 1,0 mm (soldering area); tin plated brass

### Approvals

	Current [A]	Voltage [V]	Group	AWG	[Nm]
	6	150	B		
	6	300	D		
	6	150	B		
	6	300	D		

### Options / Accessories

- Other plug pin lengths on request
- Other solder pin surfaces on request

### Part Numbers: Tape-on-Reel

No. of poles	931-SLR-THR	Tape Width	Tape Height	PU
2	12.893.721.A00	24 mm	14,8 mm	500
3	13.893.721.A00	32 mm	14,6 mm	500
4	14.893.721.A00	32 mm	14,6 mm	500
5	15.893.721.A00	32 mm	14,6 mm	500
6	16.893.721.A00	56 mm	14,6 mm	500
7	17.893.721.A00	56 mm	14,6 mm	500
8	18.893.721.A00	56 mm	14,6 mm	500
9	19.893.721.A00	56 mm	14,6 mm	500
10	20.893.721.A00	56 mm	14,6 mm	500
11	21.893.721.A00	56 mm	14,6 mm	500
12	22.893.721.A00	72 mm	14,9 mm	500
13	23.893.721.A00	72 mm	14,9 mm	500
14	24.893.721.A00	72 mm	14,9 mm	500

further number of poles on request

# 931-SLR-THR-1,1

Pin strip for THR  
Soldering/plug-in area  $\varnothing$  1,1 mm

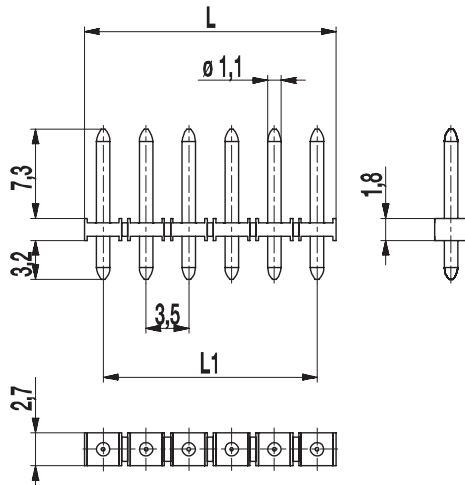

$$L1 = (\text{No. of poles} - 1) \times \text{pitch}$$

## PCB Layout

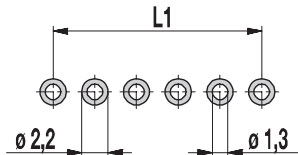

Solder paste thickness: 0,15 - 0,2 mm  
Solder pad diameter:  $\varnothing$  2,2 mm

The pin strip 931-SLR-THR-1,1 for the application in a reflow soldering process and with a pitch of 3,5 mm is available in 2 to 16 pole design.

It comes with a constant pin diameter of 1,1 mm in the solder and plug-in area. The high temperature resistant plastic housing has a very high CTI value and is equipped with spacers, so-called "Stand-offs", which ensure a better hot-air circulation during the reflow soldering process in the convection oven. Beyond this, they assure an improved optical control of the solder joints.

For the automatic assembling process, all pin strip versions are packed Tape-on-Reel and are equipped with high temperature resistant Pick Caps, which can comfortably be removed after the soldering process.

## Part Numbers

No. of poles	931-SLR-THR-1,1	Length	PU
2	32.893.727	6,50	1000
3	33.893.727	10,00	1000
4	34.893.727	13,50	500
5	35.893.727	17,00	500
6	36.893.727	20,50	500
8	38.893.727	27,50	250
10	40.893.727	34,50	200
12	42.893.727	41,50	200
16	46.893.727	55,50	200

further number of poles on request

## General Information

Pitch	3,5 mm
No. of poles	2 - 16
Usable with	plug connector 930-FL(DS)
Additional Information	Also, please take into consideration the pin strips 931-SLR-THR, 931-SLR-THR-1,3 and 931-SLR-SMD-1,3 in genuine surface mount technology.



## Technical Data

Overvoltage Category	III	III	II
Pollution Severity Level	3	2	2
Rated Voltage	160 V	160 V	320 V
Rated Impulse Voltage	2,5 kV	2,5 kV	2,5 kV
Rated Insulation Voltage	130 V acc. to EN 60998-1		
Rated Current	6 A		
Soldering process	Wave solder & reflow solder		
Hole in PCB	$\varnothing$ 1,3 mm		
PCB thickness	Wave solder max. 1,6 mm; reflow solder 1,6 - 3,2 mm		

## Material

Moulding	PA HT, black, V-0
Comparative Tracking Index	CTI $\geq$ 600
Insulating Group	I
Temperature Range	-40°C up to 120°C; reflow solder temperature peak max. 255°C acc. to DIN EN 61760-1
Solder pin	$\varnothing$ 1,1 mm; tin plated brass

## Approvals

	Current [A]	Voltage [V]	Group	AWG	[Nm]
	6	300	B, D		
	6	300	B, D		

## Options / Accessories

- Other plug pin lengths on request
- Other solder pin surfaces on request

## Part Numbers: Tape-on-Reel

No. of poles	931-SLR-THR-1,1	Tape Width	Tape Height	PU
2	32.893.727.A00	24 mm	14,8 mm	500
3	33.893.727.A00	32 mm	14,6 mm	500
4	34.893.727.A00	32 mm	14,6 mm	500
5	35.893.727.A00	32 mm	14,6 mm	500
6	36.893.727.A00	56 mm	14,6 mm	500
7	37.893.727.A00	56 mm	14,6 mm	500
8	38.893.727.A00	56 mm	14,6 mm	500
9	39.893.727.A00	56 mm	14,6 mm	500
10	40.893.727.A00	56 mm	14,6 mm	500
11	41.893.727.A00	56 mm	14,6 mm	500
12	42.893.727.A00	72 mm	14,9 mm	500
13	43.893.727.A00	72 mm	14,9 mm	500
14	44.893.727.A00	72 mm	14,9 mm	500

further number of poles on request

# 931-SLR-THR-1,3

Pin strip for THR

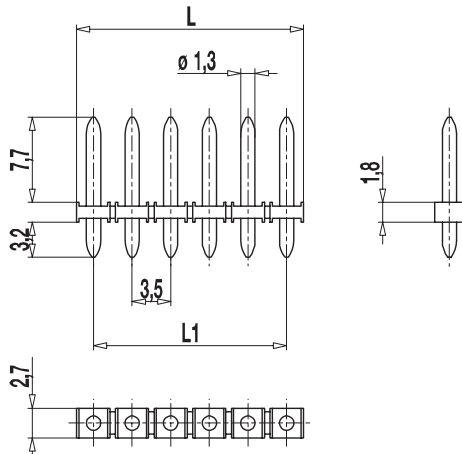
Soldering/plug-in area  $\varnothing$  1,3 mm

$$L1 = (\text{No. of poles} - 1) \times \text{pitch}$$

## PCB Layout

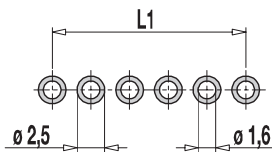

Solder paste thickness: 0,15 - 0,2 mm  
Solder pad diameter:  $\varnothing$  2,5 mm

The pin strip 931-SLR-THR-1,3 for the application in a reflow soldering process and with a pitch of 3,5 mm is available in 2 to 16 pole design.

It comes with a constant pin diameter of 1,3 mm in the solder and plug-in area.

The high temperature resistant plastic housing has a very high CTI value and is equipped with spacers, so-called "Stand-offs", which ensure a better hot-air circulation during the reflow soldering process in the convection oven. Beyond this, they assure an improved optical control of the solder joints.

For the automatic assembling process, all pin strip versions are packed Tape-on-Reel and are equipped with high temperature resistant Pick Caps, which can comfortably be removed after the soldering process.

## Part Numbers

No. of poles	931-SLR-THR-1,3	Length	PU
2	12.893.726	6,50	1000
3	13.893.726	10,00	1000
4	14.893.726	13,50	500
5	15.893.726	17,00	500
6	16.893.726	20,50	500
8	18.893.726	27,50	250
10	20.893.726	34,50	200
12	22.893.726	41,50	200
16	26.893.726	55,50	200

further number of poles on request

## General Information

Pitch	3,5 mm
No. of poles	2 - 16
Usable with	plug connector 938-FLDS
Additional Information	Also, please take into consideration the pin strips 931-SLR-SMD-1,3 in genuine surface mount technology.

## Technical Data

Overvoltage Category	III	III	II
Pollution Severity Level	3	2	2
Rated Voltage	160 V	160 V	320 V
Rated Impulse Voltage	2,5 kV	2,5 kV	2,5 kV
Rated Insulation Voltage	130 V acc. to EN 60998-1		
Rated Current	6 A		
Soldering process	Wave solder & reflow solder		
Hole in PCB	$\varnothing$ 1,6 mm		
PCB thickness	Wave solder max. 1,6 mm; reflow solder 1,6 - 3,2 mm		

## Material

Moulding	PA HT, black, V-0
Comparative Tracking Index	CTI $\geq$ 600
Insulating Group	I
Temperature Range	-40°C up to 120°C; reflow solder temperature peak max. 255°C acc. to DIN EN 61760-1
Solder pin	$\varnothing$ 1,3 mm; tin plated brass

## Approvals

	Current [A]	Voltage [V]	Group	AWG	[Nm]
	6	150	B		
	6	300	D		
	6	150	B		
	6	300	D		

## Options / Accessories

- Other plug pin lengths on request
- Other solder pin surfaces on request

## Part Numbers: Tape-on-Reel

No. of poles	931-SLR-THR-1,3	Tape Width	Tape Height	PU
2	12.893.726.A00	24 mm	14,8 mm	500
3	13.893.726.A00	32 mm	14,6 mm	500
4	14.893.726.A00	32 mm	14,6 mm	500
5	15.893.726.A00	32 mm	14,6 mm	500
6	16.893.726.A00	56 mm	14,6 mm	500
7	17.893.726.A00	56 mm	14,6 mm	500
8	18.893.726.A00	56 mm	14,6 mm	500
9	19.893.726.A00	56 mm	14,6 mm	500
10	20.893.726.A00	56 mm	14,6 mm	500
11	21.893.726.A00	56 mm	14,6 mm	500
12	22.893.726.A00	72 mm	14,9 mm	500
13	23.893.726.A00	72 mm	14,9 mm	500
14	24.893.726.A00	72 mm	14,9 mm	500

further number of poles on request



# 971-SLR-THR

Pin strip for THR

Soldering area  $\varnothing$  1 mm; plug-in area  $\varnothing$  1,3 mm

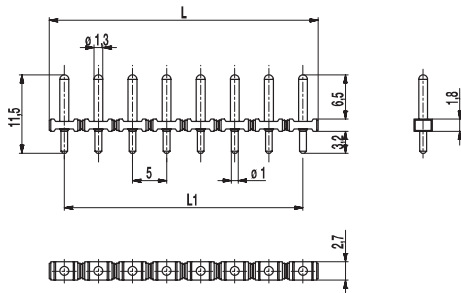

## PCB Layout

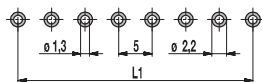

$L1 = (\text{No. of poles} - 1) \times \text{pitch}$   
 Solder paste thickness: 0,15 - 0,2 mm  
 Solder pad diameter:  $\varnothing$  2,2 mm

971-SLR-THR is a pin strip with a pitch of 5 mm for the application in a reflow soldering process. The high temperature resistant plastic housing has a very high CTI value and is equipped with spacers, so-called "Stand-offs", which ensure a better hot-air circulation during the reflow soldering process in the convection oven. Beyond this, they assure an improved optical control of the solder joints.

The pin strips of the series 971-SLR-THR comes with a stepped pin,  $\varnothing$  of 1,3 mm in the plug-in area and  $\varnothing$  of 1,0 mm in the soldering area, and is usable with all WECO plug connectors (see general information). Furthermore we recommend this pin strip for small numbers of poles and for the series of 115-F for all numbers of poles. The obtained plug-in and pullout forces are comfortable. For the automatic assembling all pin strips of this series are packed in Tape-on-Reel and equipped with high temperature resistant Pick Caps, which can easily be removed after the soldering process.

## Part Numbers

No. of poles	971-SLR-THR	Length	PU
2	12.893.801	9,50	1000
3	13.893.801	14,50	500
4	14.893.801	19,50	500
5	15.893.801	24,50	250
6	16.893.801	29,50	250
8	18.893.801	39,50	250
10	20.893.801	49,50	100
12	22.893.801	59,50	100

further number of poles on request

## General Information

Pitch	5 mm
No. of poles	2 - 12
Usable with	plug connectors of series 115-F, 950-FL-DS, 950-TFL-DS, 950-NAF-DS, 950-GFL-DS, 950-NLFL-DS, 950-RFL-DS, 970-FBW-FU(-DS)

## Technical Data

Overvoltage Category	III	III	II
Pollution Severity Level	3	2	2
Rated Voltage	250 V	320 V	630 V
Rated Impulse Voltage	4 kV	4 kV	4 kV
Rated Insulation Voltage	250 V acc. to EN 60998-1		
Rated Current	10 A		
Soldering process	Wave solder & reflow solder		
Hole in PCB	$\varnothing$ 1,3 mm		
PCB thickness	Wave solder max. 1,6 mm; reflow solder 1,6 - 3,2 mm		

## Material

Moulding	PA HT, black, V-0
Comparative Tracking Index	CTI $\geq$ 600
Insulating Group	I
Temperature Range	-40°C up to 120°C; reflow solder temperature peak max. 255°C acc. to DIN EN 61760-1
Solder pin	$\varnothing$ 1,3 mm (plug-in area) / $\varnothing$ 1,0 mm (soldering area); tin plated brass

## Approvals

	Current [A]	Voltage [V]	Group	AWG	[Nm]
	10 [1]	300	B		
	10	300	B		

[1] Above headers with 1.0 or 1.1 mm dia. pins are rated 12A max. with manufacturer's Cat. No. 120-W-111 terminal blocks. Above headers with 1.1 mm or 1.3 mm dia. pins are rated 12A max. with 115-F-111, 115-F-211 and 115-F-118 terminal blocks.

## Options / Accessories

- Other plug pin lengths on request
- Other solder pin surfaces on request

## Part Numbers: Tape-on-Reel

No. of poles	971-SLR-THR	Tape Width	Tape Height	PU
2	12.893.801.A00	32 mm	15,9 mm	500
3	13.893.801.A00	32 mm	15,9 mm	500
4	14.893.801.A00	56 mm	15,9 mm	500
6	16.893.801.A00	56 mm	15,9 mm	500
7	17.893.801.A00	56 mm	15,9 mm	500
8	18.893.801.A00	72 mm	14,9 mm	500
10	20.893.801.A00	72 mm	14,9 mm	500

further number of poles on request

# 971-SLR-THR-1,1

Pin strip for THR

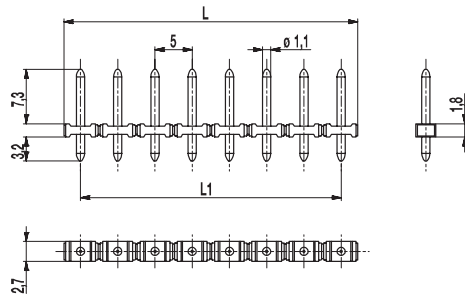
Soldering/plug-in area  $\varnothing$  1,1 mm

## PCB Layout

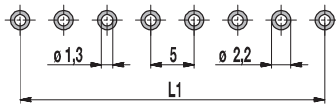

$L1 = (\text{number of poles} - 1) \times \text{pitch}$   
 Solder paste thickness: 0,15 - 0,2 mm  
 Solder pad diameter:  $\varnothing$  2,2 mm

971-SLR-THR-1.1 is a pin strip with a pitch of 5,0 mm for the application in a reflow soldering process. The high temperature resistant plastic housing has a very high CTI value and is equipped with spacers, so-called "Stand-offs", which ensure a better hot-air circulation during the reflow soldering process in the convection oven. Beyond this, they assure an improved optical control of the solder joints.

The pin strip 971-SLR-THR-1,1 comes with a constant pin  $\varnothing$  of 1,1 mm in the mating and solder area.

We recommend this pin strip for higher numbers of poles, in order to minimize the plug-in and withdrawal forces here.

For the automatic assembling all pin strips of this series are packed in Tape-on-Reel and equipped with high temperature resistant Pick Caps, which can easily be removed after the soldering process.

## Part Numbers

No. of poles	971-SLR-THR-1,1	Length	PU
2	12.893.802	9,50	1000
3	13.893.802	14,50	500
4	14.893.802	19,50	500
6	16.893.802	29,50	250
8	18.893.802	39,50	250
12	22.893.802	59,50	100

further number of poles on request

## General Information

Pitch	5 mm
No. of poles	2 - 12
Usable with	plug connectors 115-F-.../...-1,1-SW: 950-FL-DS, 950-TFL-DS, 950-NAF-DS, 950-GFL-DS, 950-NLFL-DS, 950-RFL-DS

## Technical Data

Overvoltage Category	III	III	II
Pollution Severity Level	3	2	2
Rated Voltage	250 V	320 V	630 V
Rated Impulse Voltage	4 kV	4 kV	4 kV
Rated Insulation Voltage	250 V acc. to EN 60998-1		
Rated Current	10 A		
Soldering process	Wave solder & reflow solder		
Hole in PCB	$\varnothing$ 1,3 mm		
PCB thickness	Wave solder max. 1,6 mm; reflow solder 1,6 - 3,2 mm		

## Material

Moulding	PA HT, black, V-0
Comparative Tracking Index	CTI $\geq$ 600
Insulating Group	I
Temperature Range	-40°C up to 120°C; reflow solder temperature peak max. 255°C acc. to DIN EN 61760-1
Solder pin	$\varnothing$ 1,1 mm; tin plated brass

## Approvals

	Current [A]	Voltage [V]	Group	AWG	[Nm]
	10 [1]	300	B		
	10	300	B		

[1] Above headers with 1.0 or 1.1 mm dia. pins are rated 12A max. with manufacturer's Cat. No. 120-W-111 terminal blocks. Above headers with 1.1 mm or 1.3 mm dia. pins are rated 12A max. with 115-F-111, 115-F-211 and 115-F-118 terminal blocks.

## Options / Accessories

- Other plug pin lengths on request
- Other solder pin surfaces on request

## Part Numbers: Tape-on-Reel

No. of poles	971-SLR-THR-1,1	Tape Width	Tape Height	PU
8	18.893.802.A00	72 mm	14,9 mm	500

further number of poles on request

## 971-SLR-THR-1,3

Pin strip for THR

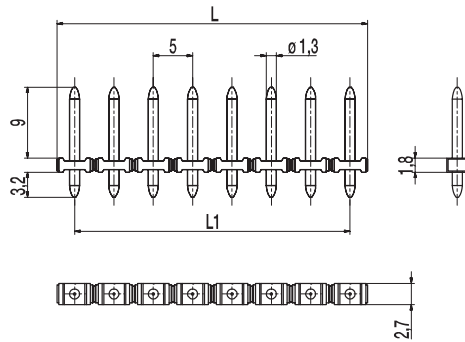
Soldering/plug-in area  $\varnothing$  1,3 mm

### PCB Layout

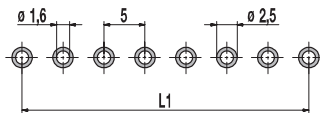

$L1 = (\text{No. of poles} - 1) \times \text{pitch}$   
Solder paste thickness: 0,15 - 0,2 mm  
Solder pad diameter:  $\varnothing$  2,5 mm

971-SLR-THR-1,3 is a pin strip with a pitch of 5 mm for the application in a reflow soldering process. The high temperature resistant plastic housing has a very high CTI value and is equipped with spacers, so-called "Stand-offs", which ensure a better hot-air circulation during the reflow soldering process in the convection oven. Beyond this, they assure an improved optical control of the solder joints.

The pin strip 971-SLR-THR-1,3 comes with a constant pin  $\varnothing$  of 1,3 mm and is usable with all WECO plug connectors (see general information). Furthermore we recommend this pin strip for small numbers of poles and for the series of 115-F for all numbers of poles. The obtained plug-in and pull-out forces are comfortable. For the automatic assembling all pin strips of this series are packed in Tape-on-Reel and equipped with high temperature resistant Pick Caps, which can easily be removed after the soldering process.

### Part Numbers

No. of poles	971-SLR-THR-1,3	Length	PU
2	12.893.805	9,50	1000
3	13.893.805	14,50	500
4	14.893.805	19,50	500
5	15.893.805	24,50	250
6	16.893.805	29,50	250
8	18.893.805	39,50	250
10	20.893.805	49,50	100
11	21.893.805	54,50	100
12	22.893.805	59,50	100

### General Information

Pitch	5 mm
No. of poles	2 - 12
Usable with	plug connectors of series 115-F, 950-FL-DS, 950-TFL-DS, 950-NAF-DS, 950-GFL-DS, 950-NLFL-DS, 950-RFL-DS



### Technical Data

Overvoltage Category	III	III	II
Pollution Severity Level	3	2	2
Rated Voltage	250 V	320 V	630 V
Rated Impulse Voltage	4 kV	4 kV	4 kV
Rated Insulation Voltage	250 V acc. to EN 60998-1		
Rated Current	10 A		
Soldering process	Wave solder & reflow solder		
Hole in PCB	$\varnothing$ 1,6 mm		
PCB thickness	Wave solder max. 1,6 mm; reflow solder 1,6 - 3,2 mm		

### Material

Moulding	PA HT, black, V-0
Comparative Tracking Index	CTI $\geq$ 600
Insulating Group	I
Temperature Range	-40°C up to 120°C; reflow solder temperature peak max. 255°C acc. to DIN EN 61760-1
Solder pin	$\varnothing$ 1,3 mm; tin plated brass

### Approvals

	Current [A]	Voltage [V]	Group	AWG	[Nm]
	10 [1]	300	B		
	10 [1]	300	B		

[1] Above headers with 1.0 or 1.1 mm dia. pins are rated 12A max. with manufacturer's Cat. No. 120-W-111 terminal blocks. Above headers with 1.1 mm or 1.3 mm dia. pins are rated 12A max. with 115-F-111, 115-F-211 and 115-F-118 terminal blocks.

### Options / Accessories

- Other plug pin lengths on request
- Other solder pin surfaces on request

### Part Numbers: Tape-on-Reel

No. of poles	971-SLR-THR-1,3	Tape Width	Tape Height	PU
2	12.893.805.A00	32 mm	15,9 mm	500
3	13.893.805.A00	32 mm	15,9 mm	500
4	14.893.805.A00	56 mm	15,9 mm	500
5	15.893.805.A00	56 mm	15,9 mm	500
6	16.893.805.A00	56 mm	15,9 mm	500
7	17.893.805.A00	56 mm	15,9 mm	500
10	20.893.805.A00	72 mm	15,9 mm	500
12	22.893.805.A00	88 mm	15,9 mm	500

further number of poles on request

[1] By using 115-F current of 12 A possible

# Pin strip as system connector



## SMD

Pitch 3.5 mm	 110-M-211-SMD 46	 110-M-216-SMD 47	 110-M-221-SMD 48	 110-M-226-SMD 49
	 120-M-211-SMD 50	 120-M-221-SMD 51		

## THR

Pitch 3.5 mm	 110-M-211-THR 52	 110-M-215-THR 53	 110-M-221-THR 54	 110-M-225-THR 55
	 120-M-211-THR 56	 120-M-221-THR 57		

Pin strips as system connector

# 110-M-211-SMD

Pin strip for SMD  
Plug-in direction parallel to PCB

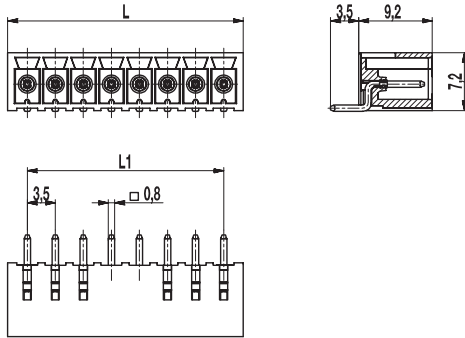

## PCB Layout

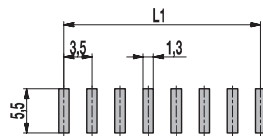

$L1 = (\text{No. of poles} - 1) \times \text{pitch}$   
Solder paste thickness: 0,2 mm

The 110-M-211-SMD is a pin strip for the reflow soldering process in a horizontal version with a pitch of 3.5 mm and available in 2 to 12 poles.

It is compatible with all standard connectors series 110 and 110-A-IDC (Insulation Displacement Contacts).

The housing of the pin strips meets the requirements of the elevated soldering temperatures in the lead-free soldering process.

## Part Numbers

No. of poles	110-M-211-SMD	Length	PU
2	10.843.102	8,40	1116
3	10.843.103	11,90	792
4	10.843.104	15,40	612
5	10.843.105	18,90	486
6	10.843.106	22,40	414
7	10.843.107	25,90	360
8	10.843.108	29,40	306
9	10.843.109	32,90	270
10	10.843.110	36,40	252
11	10.843.111	39,90	234
12	10.843.112	43,40	216

## General Information

Pitch	3,5 mm
No. of poles	2 - 12
Usable with	all plug connectors of series 110
Additional Information	Version with solder flanges see also 110-M-216-SMD



## Technical Data

Overvoltage Category	III	III	II
Pollution Severity Level	3	2	2
Rated Voltage	160 V	160 V	320 V
Rated Impulse Voltage	2,5 kV	2,5 kV	2,5 kV
Rated Insulation Voltage	130 V acc. to EN 60998-1		
Rated Current	8 A		
Soldering process	Reflow solder		

## Material

Moulding	PA HT, black, V-0
Comparative Tracking Index	CTI $\geq$ 600
Insulating Group	I
Temperature Range	-40°C up to 120°C; reflow solder temperature peak max. 255°C acc. to DIN EN 61760-1
Solder pin	0,8 x 0,8 mm; tin plated brass

## Approvals

	Current [A]	Voltage [V]	Group	AWG	[Nm]
	8	300	B, D		
	8	300	B		

## Options / Accessories

- Consecutive numbering
- Special marking according to drawing
- Self-adhesive marking strip BST-3,50 [1]
- Coding elements 120-K-HT-WS

## Part Numbers: Tape-on-Reel

No. of poles	110-M-211-SMD	Tape Width	Tape Height	PU
4	10.843.104.A00	56 mm	8 mm	475
5	10.843.105.A00	56 mm	8 mm	475
6	10.843.106.A00	56 mm	8 mm	475
7	10.843.107.A00	56 mm	8 mm	475
8	10.843.108.A00	56 mm	8 mm	475
9	10.843.109.A00	56 mm	8 mm	475
10	10.843.110.A00	56 mm	8 mm	475

further number of poles on request

[1] To be fitted after reflow soldering process

# 110-M-216-SMD

Pin strip for SMD  
 Plug-in direction parallel to PCB, with solder flanges

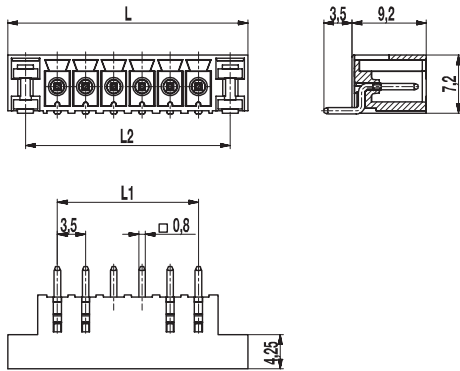

## PCB Layout

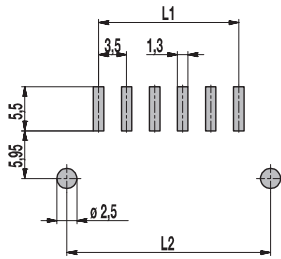

L1 = (No. of poles - 1) x pitch  
 L2 = L - 4,4  
 Solder paste thickness: 0,2 mm

The 110-M-216-SMD is a pin strip for the reflow soldering process in a horizontal version with a pitch of 3,5 mm and available in 2 to 12 poles. This product is characterized by the "Floating Anchors". They are movable in vertical direction and achieve 100% coplanarity. Side flanges improve the stability and increase the adhesion force on the PC board. The pin strip is compatible with all standard connectors series 110 and 110-A-IDC (Insulation Displacement Contacts). The housing of the pin strips meets the requirements of the elevated soldering temperatures in the lead-free soldering process.

## Part Numbers

No. of poles	110-M-216-SMD	Length	PU
2	10.843.126	15,80	594
3	10.843.127	19,30	486
4	10.843.128	22,80	414
5	10.843.129	26,30	360
6	10.843.130	29,80	306
7	10.843.131	33,30	270
8	10.843.132	36,80	252
9	10.843.133	40,30	234
10	10.843.134	43,80	216
11	10.843.135	47,30	198
12	10.843.136	50,80	180

## General Information

Pitch	3,5 mm
No. of poles	2 - 12
Usable with	all plug connectors of series 110

## Technical Data

Overvoltage Category	III	III	II
Pollution Severity Level	3	2	2
Rated Voltage	160 V	160 V	320 V
Rated Impulse Voltage	2,5 kV	2,5 kV	2,5 kV
Rated Insulation Voltage	130 V acc. to EN 60998-1		
Rated Current	8 A		
Soldering process	Reflow solder		

## Material

Moulding	PA HT, black, V-0
Comparative Tracking Index	CTI ≥ 600
Insulating Group	I
Temperature Range	40°C up to 120°C; reflow solder temperature peak max. 255°C acc. to DIN EN 61760-1
Solder pin	0,8 x 0,8 mm; tin plated brass
Solder cylinder	tin plated brass

## Approvals

	Current [A]	Voltage [V]	Group	AWG	[Nm]
	8	300	B, D		
	B	300	B		

## Options / Accessories

- Consecutive numbering
- Special marking according to drawing
- Self-adhesive marking strip BST-3,50 [1]
- Coding elements 120-K-HT-WS

## Part Numbers: Tape-on-Reel

No. of poles	110-M-216-SMD	Tape Width	Tape Height	PU
2	10.843.126.A00	56 mm	8 mm	475
3	10.843.127.A00	56 mm	8 mm	475
4	10.843.128.A00	56 mm	8 mm	475
5	10.843.129.A00	56 mm	8 mm	475
6	10.843.130.A00	56 mm	8 mm	475
7	10.843.131.A00	56 mm	8 mm	475
8	10.843.132.A00	56 mm	8 mm	475

further number of poles on request

[1] To be fitted after reflow soldering process

# 110-M-221-SMD

Pin strip for SMD  
Plug-in direction vertical to PCB

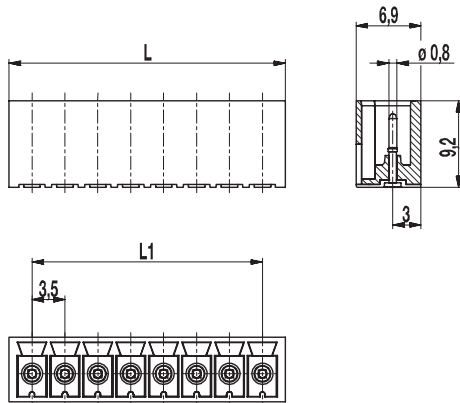

## PCB Layout

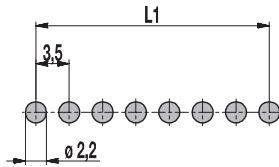

$L1 = (\text{No. of poles} - 1) \times \text{pitch}$   
Solder paste thickness: 0,15 - 0,2 mm

The 110-M-221-SMD is a pin strip for the reflow soldering process in a vertical version with a pitch of 3.5 mm and available in 2 to 12 poles. This product is characterized by the so-called "Floating Pins". They are movable in vertical direction and achieve a 100% coplanarity. It is compatible with all standard connectors series 110 and 110-A-IDC (Insulation Displacement Contacts). The housing of the pin strips meets the requirements of the elevated soldering temperatures in the lead-free soldering process. The pin strips of this series are available in Tape-on-Reel for automatic pick & place and are equipped with high temperature resistant Pick Caps which can easily be removed after the soldering process.

## Part Numbers

No. of poles	110-M-221-SMD	Length	PU
2	20.843.152	8,40	200
3	20.843.153	11,90	200
4	20.843.154	15,40	100
5	20.843.155	18,90	100
6	20.843.156	22,40	100
7	20.843.157	25,90	50
8	20.843.158	29,40	50
9	20.843.159	32,90	50
10	20.843.160	36,40	50
11	20.843.161	39,90	50
12	20.843.162	43,40	50

## General Information

Pitch	3,5 mm
No. of poles	2 - 12
Usable with	all plug connectors of series 110
Additional Information	Version with solder flanges see also 110-M-226-SMD



## Technical Data

Overvoltage Category	III	III	II
Pollution Severity Level	3	2	2
Rated Voltage	160 V	160 V	320 V
Rated Impulse Voltage	2,5 kV	2,5 kV	2,5 kV
Rated Insulation Voltage	130 V acc. to EN 60998-1		
Rated Current	8 A		
Soldering process	Reflow solder		

## Material

Moulding	PA HT, black, V-0
Comparative Tracking Index	CTI $\geq$ 600
Insulating Group	I
Temperature Range	-40°C up to 120°C; reflow solder temperature peak max. 255°C acc. to DIN EN 61760-1
Solder pin	$\varnothing$ 0,8 mm; tin plated brass

## Approvals

	Current [A]	Voltage [V]	Group	AWG	[Nm]
	8	150	B		
	8	150	B		

## Options / Accessories

- Consecutive numbering
- Special marking according to drawing
- Self-adhesive marking strip BST-3,50 [1]
- Coding elements 120-K-HT-WS

## Part Numbers: Tape-on-Reel

No. of poles	110-M-221-SMD	Tape Width	Tape Height	PU
5	20.843.155.A00	56 mm	10,9 mm	550
6	20.843.156.A00	56 mm	10,9 mm	550
7	20.843.157.A00	56 mm	10,9 mm	550
8	20.843.158.A00	56 mm	10,9 mm	550
9	20.843.159.A00	56 mm	10,9 mm	550
10	20.843.160.A00	56 mm	10,9 mm	550

further number of poles on request

[1] To be fitted after reflow soldering process

# 110-M-226-SMD

Pin strip for SMD

Plug-in direction vertical to PCB, with solder flanges

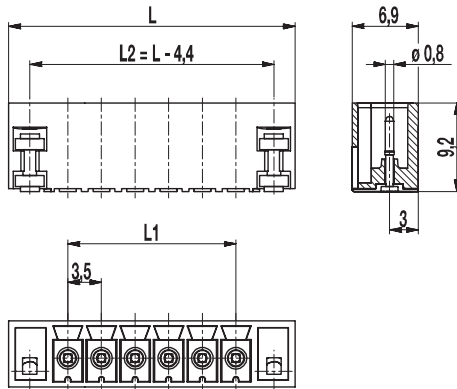

## PCB Layout

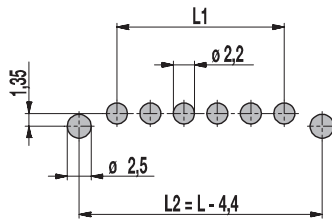

$L1 = (\text{No. of poles} - 1) \times \text{pitch}$   
Solder paste thickness: 0,15 - 0,2 mm

The 110-M-226-SMD is a pin strip for the reflow soldering process in a vertical version with a pitch of 3.5 mm and available in 2 to 12 poles.

This product is characterized by the "Floating Anchors" and "Floating Pins". They are movable in vertical direction and achieve a 100% coplanarity. Side flanges improve the stability and increase the adhesion force on the PC board.

It is compatible with all standard connectors series 110 and 110-A-IDC (Insulation Displacement Contacts).

The housing of the pin strips meets the requirements of the elevated soldering temperatures in the lead-free soldering process.

The pin strips of this series are available in Tape-on-Reel for automatic pick & place and are equipped with high temperature resistant Pick Caps which can easily be removed after the soldering process.

## Part Numbers

No. of poles	110-M-226-SMD	Length	PU
2	20.843.176	15,80	200
3	20.843.177	19,30	200
4	20.843.178	22,80	100
5	20.843.179	26,30	100
6	20.843.180	29,80	100
7	20.843.181	33,30	50
8	20.843.182	36,80	50
9	20.843.183	40,30	50
10	20.843.184	43,80	50
11	20.843.185	47,30	50
12	20.843.186	50,80	50

## General Information

Pitch	3,5 mm
No. of poles	2 - 12
Usable with	all plug connectors of series 110

## Technical Data

Overvoltage Category	III	III	II
Pollution Severity Level	3	2	2
Rated Voltage	160 V	160 V	320 V
Rated Impulse Voltage	2,5 kV	2,5 kV	2,5 kV
Rated Insulation Voltage	130 V acc. to EN 60998-1		
Rated Current	8 A		
Soldering process	Reflow solder		

## Material

Moulding	PA HT, black, V-0
Comparative Tracking Index	CTI $\geq$ 600
Insulating Group	I
Temperature Range	-40°C up to 120°C; reflow solder temperature peak max. 255°C acc. to DIN EN 61760-1
Solder pin	$\varnothing$ 0,8 mm; tin plated brass
Solder cylinder	tin plated brass

## Approvals

	Current [A]	Voltage [V]	Group	AWG	[Nm]
	8	150	B		
	8	150	B		

## Options / Accessories

- Consecutive numbering
- Special marking according to drawing
- Self-adhesive marking strip BST-3,50 [1]
- Coding elements 120-K-HT-WS

## Part Numbers: Tape-on-Reel

No. of poles	110-M-226-SMD	Tape Width	Tape Height	PU
3	20.843.177.A00	56 mm	10,9 mm	550
4	20.843.178.A00	56 mm	10,9 mm	550
5	20.843.179.A00	56 mm	10,9 mm	550
6	20.843.180.A00	56 mm	10,9 mm	550
7	20.843.181.A00	56 mm	10,9 mm	550
8	20.843.182.A00	56 mm	10,9 mm	550

further number of poles on request

[1] To be fitted after reflow soldering process



# 120-M-211-SMD

Pin strip for SMD  
Plug-in direction parallel to PCB, with side walls

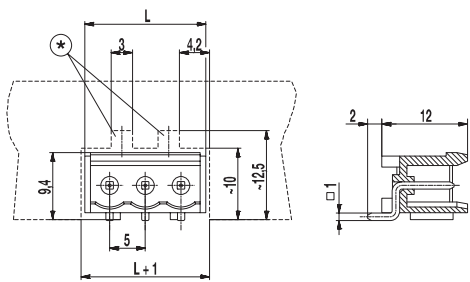
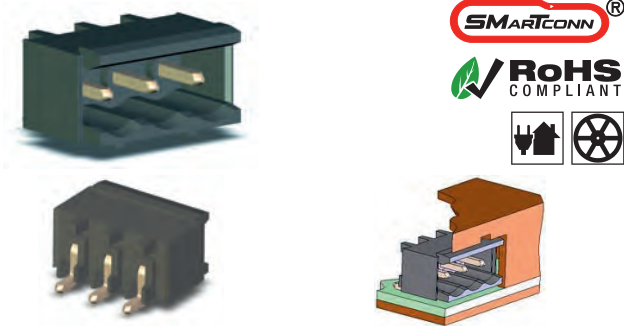

(\*) Please plan for two gaps in the measures of 3 x 2.5 mm in the cut-out of the control panel for the snap-in device of the counterpart

## PCB Layout

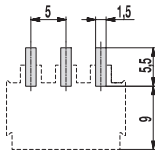

Solder paste thickness: 0,2 mm

L-shape exposed leads confer an extremely reliable retention force to PCB. This characteristic allows reliable soldering to PCB approaching zero defects for this characteristic and its effects. The top surface of the connector ensures automated Pick&Place-ability for both odd and even pole versions.

Material will handle reflow temperatures well without deforming or melting. Product shall be mounted on PCB to expose connector entry in the cut-off window of the metal or plastic enclosure. This installation mode prevents vertical peel-off stress against the L-shape solder joints during plug-in installation test. Standoffs underneath the molding ensure that connector housing keeps its horizontal position relative to PCB plane.

Packed in magazines, this genuine SMD terminal is suitable for the automatic assembly.

## Part Numbers

No. of poles	120-M-211-SMD	Length	PU
2	30.806.352	12,00	774
3	30.806.353	17,00	540
4	30.806.354	22,00	414
5	30.806.355	27,00	342
6	30.806.356	32,00	288
8	30.806.358	42,00	216

further number of poles on request

## General Information

Pitch	5 mm
No. of poles	2 - 12
Usable with	all plug connectors of series 120

## Technical Data

Overvoltage Category	III	III	II
Pollution Severity Level	3	2	2
Rated Voltage	250 V	320 V	630 V
Rated Impulse Voltage	4 kV	4 kV	4 kV
Rated Insulation Voltage	250 V acc. to EN 60998-1		
Rated Current	12 A		
Soldering process	Reflow solder		

## Material

Moulding	PA HT, black, V-0
Comparative Tracking Index	CTI ≥ 600
Insulating Group	I
Temperature Range	-40°C up to 120°C; reflow solder temperature peak max. 255°C acc. to DIN EN 61760-1
Solder pin	1,0 x 1,0 mm; tin plated brass

## Approvals

	Current [A]	Voltage [V]	Group	AWG	[Nm]
UL <sup>®</sup>	15	300	B		
	10	300	D, E		
CSA <sup>®</sup>	15	300	B		
	10	300	D, E		

## Options / Accessories

- Consecutive numbering
- Special marking according to drawing
- Self-adhesive marking strip BST-5,00 [1]
- Tape-on-Reel on request

## Part Numbers: Tape-on-Reel

No. of poles	120-M-211-SMD	Tape Width	Tape Height	PU
2	30.806.352.A00	24	10,4	375
3	30.806.353.A00	44	10,4	375
4	30.806.354.A00	44	10,4	375
5	30.806.355.A00	44	10,4	375

[1] To be fitted after reflow soldering process

# 120-M-221-SMD

Pin strip for SMD  
 Plug-in direction vertical to PCB, with side walls

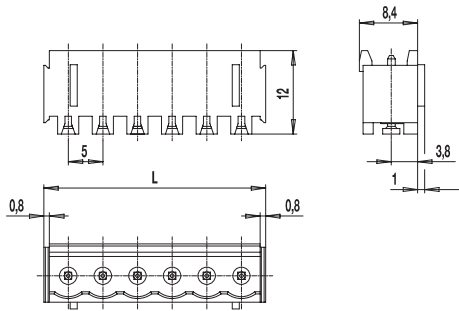

## PCB Layout

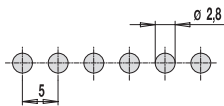

Solder paste thickness: 0,15 - 0,2 mm  
 Solder pad diameter:  $\varnothing$  2,8 mm

The PCB terminals for surface mounting comprise several types for reflow-soldering processes. Housings out of temperature resistant plastic material and solder pins in round shape with soldering foot form the pin strips of the series of 120-M-221-SMD. The pins are movable in vertical direction and this ensures plane positioning of the soldering feet on the soldering pads. Thus, 100% coplanarity is guaranteed. For the automatic assembling process, all pin strip versions are packed Tape-on-Reel and are equipped with high temperature resistant Pick Caps, which can comfortably be removed after the soldering process.

## Part Numbers

No. of poles	120-M-221-SMD	Length	PU
2	40.806.352	12,00	200
3	40.806.353	17,00	200
4	40.806.354	22,00	100
5	40.806.355	27,00	100
6	40.806.356	32,00	100
8	40.806.358	42,00	50
10	40.806.360	52,00	50
12	40.806.362	62,00	50

further number of poles on request

## General Information

Pitch	5 mm
No. of poles	2 - 12
Usable with	all plug connectors of series 120

## Technical Data

Overvoltage Category	III	III	II
Pollution Severity Level	3	2	2
Rated Voltage	160 V	160 V	250 V
Rated Impulse Voltage	2,5 kV	2,5 kV	2,5 kV
Rated Insulation Voltage	130 V acc. to EN 60998-1		
Rated Current	12 A		
Soldering process	Reflow solder		

## Material

Moulding	PA HT, black, V-0
Comparative Tracking Index	CTI $\geq$ 600
Insulating Group	I
Temperature Range	-40°C up to 120°C; reflow solder temperature peak max. 255°C acc. to DIN EN 61760-1
Solder pin	$\varnothing$ 1,1 mm (plug-in area); tin plated brass

## Approvals

	Current [A]	Voltage [V]	Group	AWG	[Nm]
UL®	15	300	B		
	10	300	D		
CSA®	15	300	B		
	10	300	D, E		

## Options / Accessories

- Consecutive numbering
- Special marking according to drawing
- Self-adhesive marking strip BST-5,00 [1]

## Part Numbers: Tape-on-Reel

No. of poles	120-M-221-SMD	Tape Width	Tape Height	PU
2	40.806.352.A00	32 mm	17,4 mm	225
3	40.806.353.A00	32 mm	17,4 mm	225
4	40.806.354.A00	56 mm	17,4 mm	225
5	40.806.355.A00	56 mm	17,4 mm	225
6	40.806.356.A00	56 mm	17,4 mm	225
7	40.806.357.A00	56 mm	17,4 mm	225

further number of poles on request

[1] To be fitted after reflow soldering process

# 110-M-211-THR

Pin strip for THR  
Plug-in direction parallel to PCB

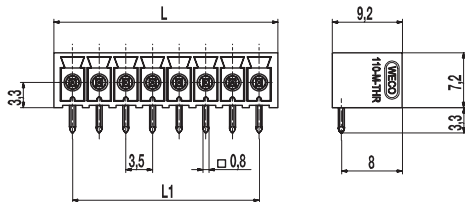

## PCB Layout

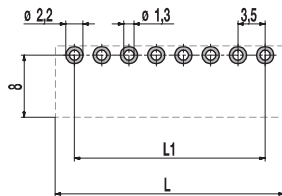

$L1 = (\text{No. of poles} - 1) \times \text{pitch}$   
Solder paste thickness: 0,15 - 0,2 mm

The 110-M-211-THR is a pin strip, suitable for the reflow soldering process, in horizontal design with a pitch of 3,5 mm and available from 2 to 12 poles. It is compatible to all standard plugs of the series 110 as well as to the Insulation Displacement Connector 110-A-IDC.

The housing of the pin strips correspond to the requirements of the increased soldering temperatures in the lead free soldering process. Spacers, so-called stand-offs, ensure a better hot-air circulation during the reflow soldering process in the convection oven and allow an improved visual control of the solder joint.

All THR pin strips of this series are packed Tape-on-Reel for the assembling with pick & place machines.

## Part Numbers

No. of poles	110-M-211-THR	Length	PU
2	10.841.302	8,40	200
3	10.841.303	11,90	200
4	10.841.304	15,40	100
5	10.841.305	18,90	100
6	10.841.306	22,40	100
7	10.841.307	25,90	50
8	10.841.308	29,40	50
9	10.841.309	32,90	50
10	10.841.310	36,40	50
11	10.841.311	39,90	50
12	10.841.312	43,40	50

## General Information

Pitch	3,5 mm
No. of poles	2 - 12
Usable with	all plug connectors of series 110
Additional Information	Version with connecting flanges see also 110-M-215-THR



## Technical Data

Overvoltage Category	III	III	II
Pollution Severity Level	3	2	2
Rated Voltage	160 V	160 V	320 V
Rated Impulse Voltage	2,5 kV	2,5 kV	2,5 kV
Rated Insulation Voltage	130 V acc. to EN 60998-1		
Rated Current	8 A		
Soldering process	Wave solder & reflow solder		
Hole in PCB	ø 1,3 mm		
PCB thickness	Wave solder max. 1,6 mm; reflow solder 1,6 - 3,2 mm		

## Material

Moulding	PA HT, black, V-0
Comparative Tracking Index	CTI ≥ 600
Insulating Group	I
Temperature Range	-40°C up to 120°C; reflow solder temperature peak max. 255°C acc. to DIN EN 61760-1
Solder pin	0,8 x 0,8 mm; tin plated brass

## Approvals

	Current [A]	Voltage [V]	Group	AWG	[Nm]
	8	300	B, D		
	8	300	B		

## Options / Accessories

- Consecutive numbering
- Special marking according to drawing
- Self-adhesive marking strip BST-3,50 [1]
- Coding elements 120-K-HT-WS

## Part Numbers: Tape-on-Reel

No. of poles	110-M-211-THR	Tape Width	Tape Height	PU
2	10.841.302.A00	32 mm	11,8 mm	500
3	10.841.303.A00	32 mm	11,8 mm	500
4	10.841.304.A00	32 mm	11,8 mm	500
5	10.841.305.A00	32 mm	11,8 mm	500

further number of poles on request

[1] To be fitted after reflow soldering process

# 110-M-215-THR

Pin strip for THR

Plug-in direction parallel to PCB, with connecting flanges

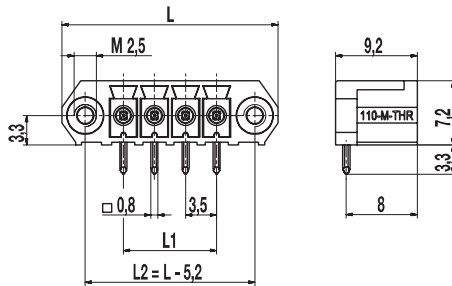

## PCB Layout

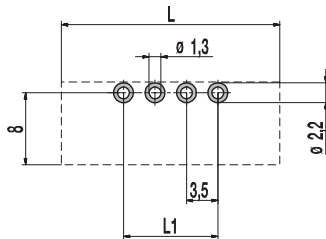

$L1 = (\text{No. of poles} - 1) \times \text{pitch}$   
Solder paste thickness: 0,15 - 0,2 mm

The 110-M-215-THR is a pin strip, suitable for the reflow soldering process, in horizontal design with a pitch of 3,5 mm and available in 2- to 12-pole design.

It is compatible to all standard plugs of the series 110 as well as to the Insulation Displacement Connector 110-A-IDC.

This version has connecting flanges with thread inserts M2,5 (<0,3 Nm) on both sides of the connector which extend the range of applications additionally.

The housing of the pin strips correspond to the requirements of the increased soldering temperatures in the lead free soldering process. Spacers, so-called stand-offs, ensure a better hot-air circulation during the reflow soldering process in the convection oven and allow an improved visual control of the solder joint.

All THR pin strips of this series are packed in Tape-on-Reel for automatic pick & place and are equipped with high temperature resistant pick caps which can easily be removed after the soldering process.

## Part Numbers

No. of poles	110-M-215-THR	Length	PU
2	10.841.352	17,30	100
3	10.841.353	20,80	100
4	10.841.354	24,30	100
5	10.841.355	27,80	50
6	10.841.356	31,30	50
8	10.841.358	38,30	50
10	10.841.360	45,30	50
11	10.841.361	48,80	50
12	10.841.362	52,30	50

## General Information

Pitch	3,5 mm
No. of poles	2 - 12
Usable with	all plug connectors of series 110 with connecting flanges

## Technical Data

Overvoltage Category	III	III	II
Pollution Severity Level	3	2	2
Rated Voltage	160 V	160 V	320 V
Rated Impulse Voltage	2,5 kV	2,5 kV	2,5 kV
Rated Insulation Voltage	130 V acc. to EN 60998-1		
Rated Current	8 A		
Soldering process	Wave solder & reflow solder		
Hole in PCB	ø 1,3 mm		
PCB thickness	Wave solder max. 1,6 mm; reflow solder 1,6 mm - 3,2 mm		

## Material

Moulding	PA HT, black, V-0
Comparative Tracking Index	CTI ≥ 600
Insulating Group	I
Temperature Range	-40°C up to 120°C; reflow solder temperature peak max. 255°C acc. to DIN EN 61760-1
Solder pin	0,8 x 0,8 mm; tin plated brass

## Approvals

	Current [A]	Voltage [V]	Group	AWG	[Nm]
	8	300	B, D		
	8	300	B		

## Options / Accessories

- Consecutive numbering
- Special marking according to drawing
- Self-adhesive marking strip BST-3,50 [1]
- Coding elements 120-K-HT-WS

## Part Numbers: Tape-on-Reel

No. of poles	110-M-215-THR	Tape Width	Tape Height	PU
2	10.841.352.A00	32 mm	11,8 mm	500
3	10.841.353.A00	32 mm	11,8 mm	500

further number of poles on request

[1] To be fitted after reflow soldering process

# 110-M-221-THR

Pin strip for THR  
Plug-in direction vertical to PCB

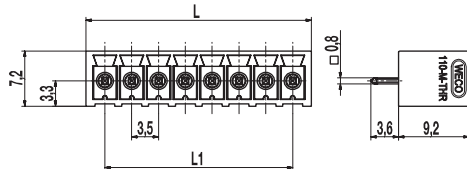

## PCB Layout

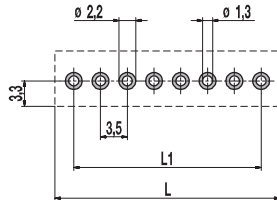

$L1 = (\text{No. of poles} - 1) \times \text{pitch}$   
Solder paste thickness: 0,15 - 0,2 mm

The 110-M-221-THR is a pin strip, suitable for the reflow soldering process, in vertical design with a pitch of 3,5 mm and available from 2 to 12 poles. It is compatible to all standard plugs of the series 110 as well as to the Insulation Displacement Connector 110-A-IDC.

The housing of the pin strips correspond to the requirements of the increased soldering temperatures in the lead free soldering process. Spacers, so-called stand-offs, ensure a better hot-air circulation during the reflow soldering process in the convection oven and allow an improved visual control of the solder joint.

All THR pin strips of this series are packed Tape-on-Reel for the assembling with pick & place machines. They are equipped with high temperature resistant Pick Caps (see picture), which can be comfortably removed after the soldering process.

## Part Numbers

No. of poles	110-M-221-THR	Length	PU
2	20.841.302	8,40	200
3	20.841.303	11,90	200
4	20.841.304	15,40	100
5	20.841.305	18,90	100
6	20.841.306	22,40	100
7	20.841.307	25,90	50
8	20.841.308	29,40	50
9	20.841.309	32,90	50
10	20.841.310	36,40	50
11	20.841.311	39,90	50
12	20.841.312	43,40	50

## General Information

Pitch	3,5 mm
No. of poles	2 - 12
Usable with	all plug connectors of series 110
Additional Information	Version with connecting flanges see also 110-M-225-THR



## Technical Data

Overvoltage Category	III	III	II
Pollution Severity Level	3	2	2
Rated Voltage	160 V	160 V	320 V
Rated Impulse Voltage	2,5 kV	2,5 kV	2,5 kV
Rated Insulation Voltage	130 V acc. to EN 60998-1		
Rated Current	8 A		
Soldering process	Wave solder & reflow solder		
Hole in PCB	ø 1,3 mm		
PCB thickness	Wave solder max. 1,6 mm; reflow solder 1,6 mm - 3,2 mm		

## Material

Moulding	PA HT, black, V-0
Comparative Tracking Index	CTI ≥ 600
Insulating Group	I
Temperature Range	-40°C up to 120°C; reflow solder temperature peak max. 255°C acc. to DIN EN 61760-1
Solder pin	0,8 x 0,8 mm; tin plated brass

## Approvals

	Current [A]	Voltage [V]	Group	AWG	[Nm]
	8	300	B, D		
	8	300	B		

## Options / Accessories

- Consecutive numbering
- Special marking according to drawing
- Self-adhesive marking strip BST-3,50 [1]
- Coding elements 120-K-HT-WS

## Part Numbers: Tape-on-Reel

No. of poles	110-M-221-THR	Tape Width	Tape Height	PU
5	20.841.305.A00	56 mm	14,9 mm	300
6	20.841.306.A00	56 mm	14,9 mm	300
7	20.841.307.A00	56 mm	14,9 mm	300
8	20.841.308.A00	56 mm	14,9 mm	300
9	20.841.309.A00	56 mm	14,9 mm	300
10	20.841.310.A00	56 mm	14,9 mm	300

further number of poles on request

[1] To be fitted after reflow soldering process

# 110-M-225-THR

Pin strip for THR

Plug-in direction vertical to PCB, with connecting flanges

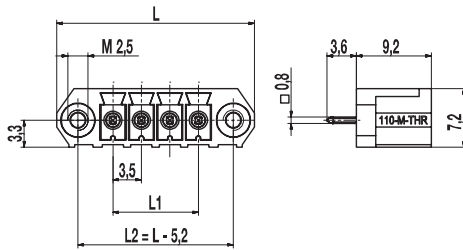

## PCB Layout

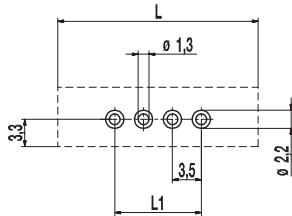

$L1 = (\text{No. of Poles} - 1) \times \text{pitch}$   
Solder paste thickness: 0,15 - 0,2 mm

The 110-M-225-THR is a pin strip, suitable for the reflow soldering process, in vertical design with a pitch of 3,5 mm and available in 2- to 12-pole design.

It is compatible to all standard plugs of the series 110 as well as to the Insulation Displacement Connector 110-A-IDC.

This version has connecting flanges with thread inserts M2,5 (<0,3 Nm) on both sides of the connector which extend the range of applications additionally.

The housing of the pin strips correspond to the requirements of the increased soldering temperatures in the lead free soldering process. Spacers, so-called stand-offs, ensure a better hot-air circulation during the reflow soldering process in the convection oven and allow an improved visual control of the solder joint.

All THR pin strips of this series are packed in Tape-on-Reel for automatic pick & place and are equipped with high temperature resistant pick caps which can easily be removed after the soldering process.

## Part Numbers

No. of poles	110-M-225-THR	Length	PU
2	20.841.352	17,30	100
3	20.841.353	20,80	100
4	20.841.354	24,30	100
5	20.841.355	27,80	50
6	20.841.356	31,30	50
8	20.841.358	38,30	50
10	20.841.360	45,30	50
11	20.841.361	48,80	50
12	20.841.362	52,30	50

## General Information

Pitch	3,5 mm
No. of poles	2 - 12
Usable with	all plug connectors of series 110 with connecting flanges

## Technical Data

Overvoltage Category	III	III	II
Pollution Severity Level	3	2	2
Rated Voltage	160 V	160 V	320 V
Rated Impulse Voltage	2,5 kV	2,5 kV	2,5 kV
Rated Insulation Voltage	130 V acc. to EN 60998-1		
Rated Current	8 A		
Soldering process	Wave solder & reflow solder		
Hole in PCB	ø 1,3 mm		
PCB thickness	Wave solder max. 1,6 mm; reflow solder 1,6 mm - 3,2 mm		

## Material

Moulding	PA HT, black, V-0
Comparative Tracking Index	CTI ≥ 600
Insulating Group	I
Temperature Range	-40°C up to 120°C; reflow solder temperature peak max. 255°C acc. to DIN EN 61760-1
Solder pin	0,8 x 0,8 mm; tin plated brass

## Approvals

	Current [A]	Voltage [V]	Group	AWG	[Nm]
	8	300	B, D		
	8	300	B		

## Options / Accessories

- Consecutive numbering
- Special marking according to drawing
- Self-adhesive marking strip BST-3,50 [1]
- Coding elements 120-K-HT-WS

## Part Numbers: Tape-on-Reel

No. of poles	110-M-225-THR	Tape Width	Tape Height	PU
3	20.841.353.A00	56 mm	14,9 mm	300
4	20.841.354.A00	56 mm	14,9 mm	300
5	20.841.355.A00	56 mm	14,9 mm	300
6	20.841.356.A00	56 mm	14,9 mm	300
7	20.841.357.A00	56 mm	14,9 mm	300
8	20.841.358.A00	56 mm	14,9 mm	300

further number of poles on request

[1] To be fitted after reflow soldering process

# 120-M-211-THR

Pin strip for THR

Plug-in direction parallel to PCB, with side walls

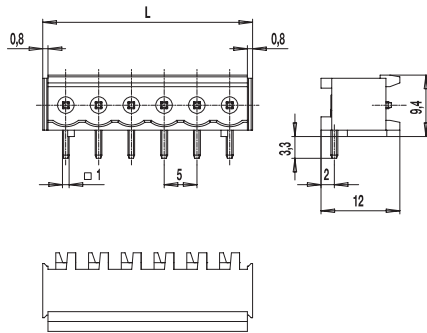
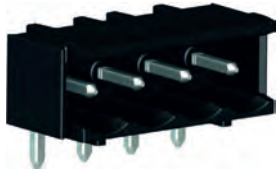

## PCB Layout

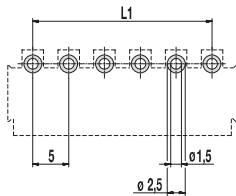

$L1 = (\text{No. of poles} - 1) \times \text{pitch}$   
Solder paste thickness: 0,15 - 0,2 mm  
Solder pad diameter:  $\varnothing 2,5$  mm

The products based on our established 120 series (conecta) have been designed for the soldering process in Through-Hole-Reflow technology.

The soldering paste is applied to the plated through holes and the pins are placed in the circuit board and soldered by a reflow oven.

The terminal mouldings are made of heat-resistant material. The stand-offs on the base ensures there is enough room for the soldering paste and facilitates good heat circulation for optimum soldering and enables the soldering joint to be visually inspected.

The solder pin projects very slightly with a circuit board thickness of 1,6 mm, creates a solder point on both sides, and thus guarantees a secure mounting. The position of the solder pins enables an equally minimal allocation area on the circuit board as with wave soldering.

## Part Numbers

No. of poles	120-M-211-THR	Length	PU
2	10.806.352	12,00	200
3	10.806.353	17,00	200
4	10.806.354	22,00	100
5	10.806.355	27,00	100
6	10.806.356	32,00	100
8	10.806.358	42,00	50
10	10.806.360	52,00	50
12	10.806.362	62,00	50

further number of poles on request

## General Information

Pitch	5 mm
No. of poles	2 - 12
Usable with	all plug connectors of series 120
Additional Information	The 120-M-THR pin strips are, like the conventional products, available with straight or angled soldering pins for vertical or parallel plugging of the mating parts, whereby all plugs of the conecta series 120-A, -D, and -F can be used.



## Technical Data

Overvoltage Category	III	III	II
Pollution Severity Level	3	2	2
Rated Voltage	250 V	320 V	630 V
Rated Impulse Voltage	4 kV	4 kV	4 kV
Rated Insulation Voltage	250 V acc. to EN 60998-1		
Rated Current	12 A		
Soldering process	Wave solder & reflow solder		
Hole in PCB	$\varnothing 1,5$ mm		
PCB thickness	Wave solder max. 1,6 mm; reflow solder 1,6 - 3,2 mm		

## Material

Moulding	PA HT, black, V-0
Comparative Tracking Index	CTI $\geq 600$
Insulating Group	I
Temperature Range	-40°C up to 120°C; reflow solder temperature peak max. 255°C acc. to DIN EN 61760-1
Solder pin	1,0 x 1,0 mm; tin plated brass

## Approvals

	Current [A]	Voltage [V]	Group	AWG	[Nm]
	15	300	B		
	10	300	D		
	15	300	B		
	10	300	D, E		

## Options / Accessories

- Consecutive numbering
- Special marking according to drawing
- Self-adhesive marking strip BST-5,00 [1]
- Special packaging on request: Tape-on-Reel - Tray - Bar magazine

[1] To be fitted after reflow soldering process

# 120-M-221-THR

Pin strip for THR  
 Plug-in direction vertical to PCB, with side walls

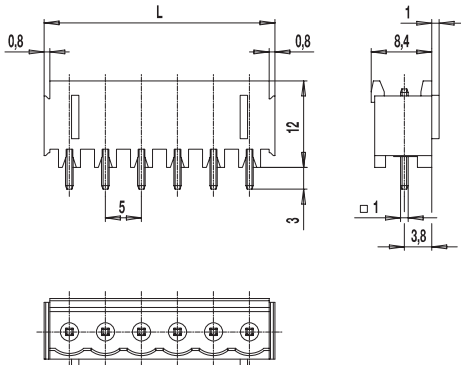
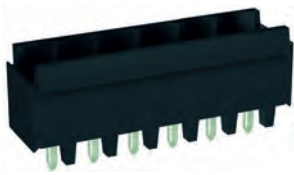

## PCB Layout

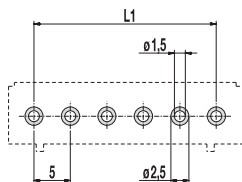

$L1 = (\text{No. of poles} - 1) \times \text{pitch}$   
 Solder paste thickness: 0,15 - 0,2 mm  
 Solder pad diameter:  $\varnothing$  2,5 mm

The products based on our established 120-M series (conecta) have been designed for the soldering process in Through-Hole-Reflow technology. The soldering paste is applied to the plated through holes and the pins are placed in the circuit board and soldered by a reflow oven. The terminal mouldings are made of heat-resistant material. The stand-offs on the base ensures there is enough room for the soldering paste and facilitates good heat circulation for optimum soldering and enables the soldering joint to be visually inspected. The solder pin projects very slightly with a circuit board thickness of 1,6 mm, creates a solder point on both sides, and thus guarantees a secure mounting. The position of the solder pins enables an equally minimal allocation area on the circuit board as with wave soldering. The 120-M-THR pin strips are, like the conventional products, available with straight or angled soldering pins for vertical or parallel plugging of the mating parts, whereby all plugs of the conecta series 120-A, -D, and -F can be used.

## Part Numbers

No. of poles	120-M-221-THR	Length	PU
2	20.806.352	12,00	200
3	20.806.353	17,00	200
4	20.806.354	22,00	100
6	20.806.356	32,00	100
8	20.806.358	42,00	50
10	20.806.360	52,00	50
12	20.806.362	62,00	50

further number of poles on request

## General Information

Pitch	5 mm
No. of poles	2 - 12
Usable with	all plug connectors of series 120
Additional Information	For the automatic assembling process, all pin strip versions are packed Tape-on-Reel and are equipped with high temperature resistant Pick Caps, which can comfortably be removed after the soldering process.

## Technical Data

Overvoltage Category	III	III	II
Pollution Severity Level	3	2	2
Rated Voltage	250 V	320 V	630 V
Rated Impulse Voltage	4 kV	4 kV	4 kV
Rated Insulation Voltage	250 V acc. to EN 60998-1		
Rated Current	12 A		
Soldering process	Wave solder & reflow solder		
Hole in PCB	$\varnothing$ 1,5 mm		
PCB thickness	Wave solder max. 1,6 mm; reflow solder 1,6 - 3,2 mm		

## Material

Moulding	PA HT, black, V-0
Comparative Tracking Index	CTI $\geq$ 600
Insulating Group	I
Temperature Range	-40°C up to 120°C; reflow solder temperature peak max. 255°C acc. to DIN EN 61760-1
Solder pin	1,0 x 1,0 mm; tin plated brass

## Approvals

	Current [A]	Voltage [V]	Group	AWG	[Nm]
UL®	15	300	B		
	10	300	D		
SP®	15	300	B		
	10	300	D, E		

## Options / Accessories

- Consecutive numbering
- Special marking according to drawing
- Self-adhesive marking strip BST-5,00 [1]

## Part Numbers: Tape-on-Reel

No. of poles	120-M-221-THR	Tape Width	Tape Height	PU
2	20.806.352.A00	32 mm	17,4 mm	225
3	20.806.353.A00	32 mm	17,4 mm	225
4	20.806.354.A00	56 mm	17,4 mm	225
5	20.806.355.A00	56 mm	17,4 mm	225
6	20.806.356.A00	56 mm	17,4 mm	225
7	20.806.357.A00	56 mm	17,4 mm	225

further number of poles on request

[1] To be fitted after reflow soldering process



# Coding systems

## Coding element 120-K

Coding elements 120-K can be used for the conecta series 110, 120, 121, and 122.

All pin strips and plug connectors of those series (except for series 110, please refer to coding examples) feature one trapezoidal coding groove per pole, in which the coding elements can be

inserted.

This simple solution guarantees error-free plugging.

In their standard design, coding elements are of bright red colour making them clearly visible in plugged condition.

Alternatively, they are also available in

light grey and white. Red and light grey versions are delivered in strips of 12 coding keys. White coding elements are delivered loosely in a bag.



Part number	Type	Colour	PU
20.496.025	120-K/12 KODIEREL.	■ red	120
17.496.025	120-K/12 KODIEREL. LG	■ light grey	120
30.496.026	120-K/01-HT-WS-KOD.EL. (Lose)	□ white	100

### Usable with:

- Plug connectors: 120-A-..., 120-D-..., 120-F-..  
 121-A-..., 121-C-..., 121-D-..., 121-F-..  
 122-A-..., 122-D-..., 122-F-..  
 Pin strips: 110-M-..., 110-P-..., 110-S-..., 110-V-..  
 120-M-..  
 121-M-..  
 122-M-..

### Coding examples

As standard, terminal strips of series 110 come with coding elements, which can be cut off, if necessary. The pin strips feature slots to accommodate coding elements 120-K.

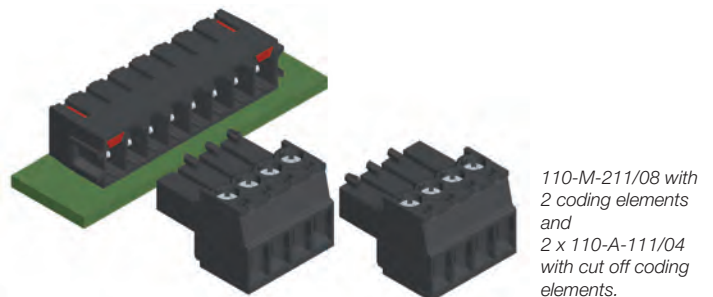

Plug connectors and terminal strips of series 120, 121 and 122 feature grooves to attach coding elements 120-K. Upon request, fixed-coded plug connectors are available.

For such plug connectors and pin strips, the coding element geometry is formed by the injection moulding.

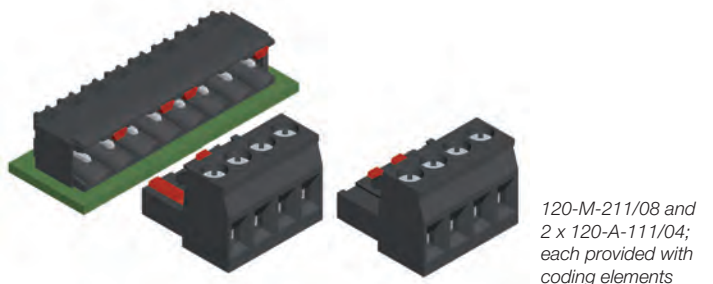

# Marking

WECO offers marking of individual connections for nearly all terminals and products.

## Marking strips

Self-adhesive marking strips consist of polyester with black print on silver background. They are scratch-proof and surface-sealed with Mylar.

The numbering begins with „1“. The last digit represents the indicated number of poles.

The marking strips withstand PC board

cleaning processes using water and soap, Freon, fluorinated or chlorinated cleaning agents. However, they are not reflow-capable and should therefore only be mounted after the reflow soldering process.

Marking strips are delivered in ten strips per sheet.



Part number	Type	Marking	Pitch	Length (L)	Width (a)	PU
24.499.013	BST-3,50/24	1 2 3 ... 24	3,50 mm	84 mm	3 mm	100
24.499.009	BST-5,00/12	1 2 3 ... 12	5,00 mm	60 mm	3,5 mm	100
24.499.010	BST-5,00/32	1 2 3 ... 32	5,00 mm	160 mm	3,5 mm	100
24.499.006	BST-5,08/12	1 2 3 ... 12	5,08 mm	61 mm	3,5 mm	100
24.499.007	BST-5,08/32	1 2 3 ... 32	5,08 mm	162 mm	3,5 mm	100
24.499.012	BST-7,50/19	1 2 3 ... 19	7,50 mm	141 mm	3,5 mm	100
24.499.011	BST-10,00/16	1 2 3 ... 16	10,00 mm	155 mm	3,5 mm	100
24.499.008	BST-10,16/16	1 2 3 ... 16	10,16 mm	157 mm	3,5 mm	100

## InkJet printing

As an alternative to self-adhesive marking strips, we also offer markings according to your specific requirements. Our products are marked by means of inkjet printers. Micro-sized ink droplets are shot accurately to the point and guided by an electric field thus creating the high-precision print – very much like a printed pattern generated by a common matrix printer. This process is fast, easy-to-use and reprogrammable. However, this printing process comprises of the contour precision of the print. In addition to numbers and letters, special characters can also be printed. The inkjet print features tried and tested scratch- and wipe-resistance.

Standard marking for PCB connectors comes in either black or white - depending on the housing colour. The marking is printed on given surfaces.

Markings for our connectors featured in catalogue 7 are printed in black. Markings may be printed in two locations: either on or between the screw guides (for series 302 only on the screw guides).

Alternatively, WECO offers for special colours pad printed markings. Due to the elaborate handling it makes this printing method, however, significantly more expensive.



*InkJet printing  
(graphic illustration)*

## Packaging

As standard, we deliver our products packaged in eco-friendly folding boxes made of cardboard or corrugated board.



In order to ensure efficient automated assembly and subsequent soldering of our components, WECO offers various component packaging systems, such as

### Tape-on-Reel



These carrier tapes on reels are suitable for most SMD and THR components. They feature blisters and are sealed with a cover film.

WECO offer reels in different widths of 24 mm, 32 mm, 44 mm, 56 mm, 72 mm or 88 mm.

### Trays



WECO also offers trays as another option for automated component assembly. The flat trays feature component pockets, they are stackable and ensure sufficiently large component supply.

### Bar magazines



Our 550 mm bar magazines have various geometries which are tailored to the individual component size and shape. Both magazine ends are closed with a plug that is easy to remove.

Delivered in cardboard folding boxes, bar magazines are easy to unpack.

When assembling components from tape-on-reels or trays, the placement head vacuum-picks the component from the tape or the tray, verifies the position by means of a camera system, calculates angle and position offset to the nominal position and places the component onto the PC board. After all components have been placed, a conveyor system transports the assembled PC board downstream.



All three component packaging types use anti-static materials to avoid problems with electrostatic discharges (ESD).

# Other options

## Moulding colours

WECO offers a multitude of various moulding colours.

In addition to our standard colours charcoal grey, black, vermilion and natural other moulding colours are also possible.

Please contact us for further information, we look forward to assisting you.

### Standard colours

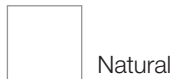
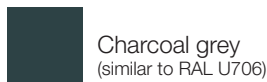

### Special colours

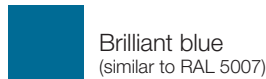
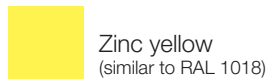
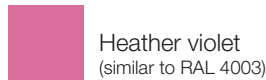

### Standard colours for SMD & THR products

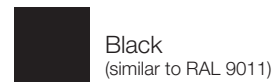

## Screws

We use standard slotted-head screws for our products.

Upon inquiry and specific customer request, we also offer screws with Phillips/ Pozidriv or +/- screw heads.

Other materials:

Our products are predominantly equipped with steel screws. Upon request, screws made of alternative materials, such as brass, are also available.

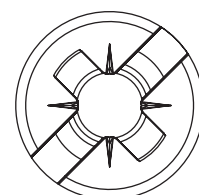
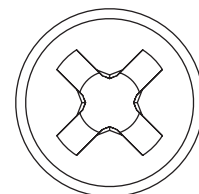

# Soldering processes

As a principle, soldering electrically and mechanically connects electronic components to printed circuits forming a subassembly.

The solder contributes essentially to the operational reliability of an assembly. Among the various soldering methods, such as reflow soldering and wave soldering, Surface-Mount-Technology

(SMT) using reflow soldering is the most common and cost-efficient process.



The shown tables represents two solder temperature profiles compliant with EN 61760-1. Due to the various customer-specific parameters (e.g. soldering system, solder paste, component arrangement and orientation) the profiles are only recommendations and should be used accordingly.

## Reflow soldering

During the reflow soldering process, printed circuit boards assembled with SMD and THR components, are passed at a constant speed through various heating zones of a furnace (preheating, reflow soldering and furnace cooling).

In contrast to wave soldering, components and their plastic packages are exposed to the same temperatures as the metallic contacts to be soldered. Electrical components, printed circuit boards and solder joints are heated either by infrared, convection or a vapor phase processes. In order to avoid oxidation of the solder pads on the printed circuit, this process can also be conducted under inert atmosphere.

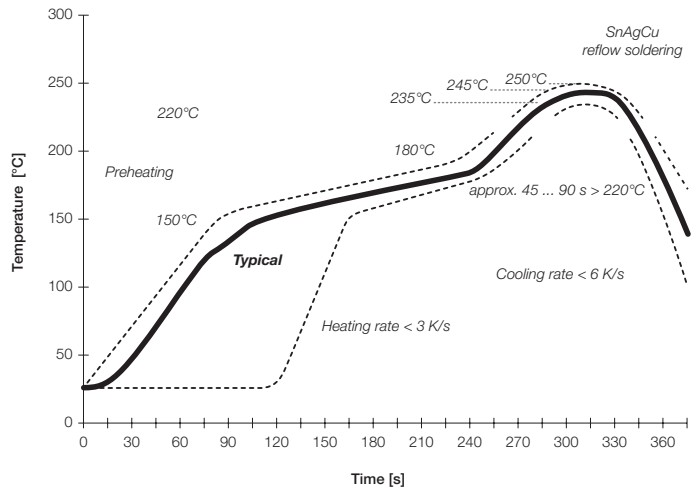

## Wave soldering

Wave soldering processes are suitable for soldering conventional components. A conveyor system moves the PCB through the soldering system at a constant speed. Upstream in the wave soldering system, the PCB and its components pass through the fluxer. Downstream in the preheating zone, the solvents contained in the fluxer are vaporized thus activating the flux. Liquid solder is continuously pumped flowing over edges, through holes or into gaps, forming a wave of solder. This solder wave conveys and wets the underside of the printed circuit. Capillary forces raise the solder through the space between hole and component lead (solder pin) forming the characteristic solder meniscus.

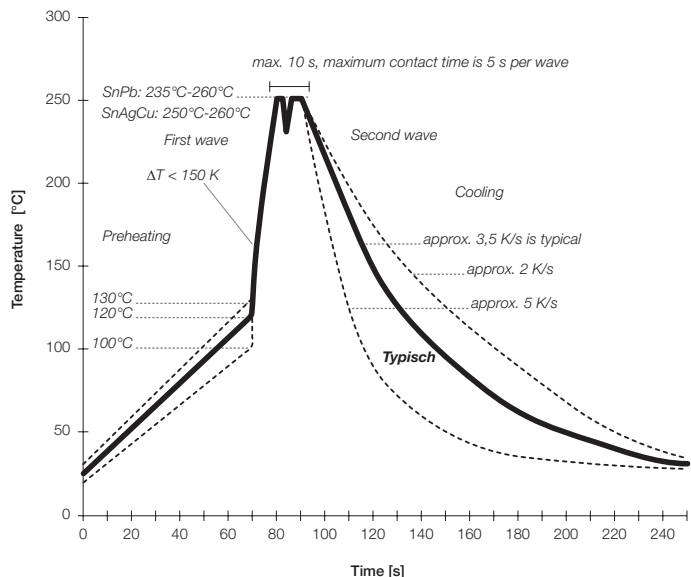

# Technical Information

## Rating of clearance and creepage distances according to DIN EN 60664-1 (VDE 0110-1)

The rating of clearance and creepage distances depends on the expected electrical surge, the characteristic values of the electronic protection measures as well as the contamination at the place of installation.

Clearance distances are dimensioned in accordance with the rated impulse voltage (see table F.1), which results out of the overvoltage category and phase-to-earth voltage.

The minimum clearance in air is stated at altitudes of less than 2000 m above sea level and ascertained in accordance with the impulse voltage and the contamination level, see table F.2.

Creepage distances are measured by the operating voltage, the characteristic of the insulants (CTI value), the expected contamination level as well as the preventive measures against contamination.

Basis of the creepage distance is the rated voltage derived from the operating and / or system voltage.

The minimum creepage distance (depending on the respective degree of contamination) are assigned to the rated voltage, see table F.4.

### Overvoltage categories

#### Overvoltage category IV

Electrical equipments for the use at the connection point of the installation e.g. electricity meter and primary over-current protection devices.

#### Overvoltage category III

Electrical equipment in firm installations and for such cases in which special demands are made against the reliability

### F.1 DIN EN 60664-1 (VDE 0110-1), table F.1 (extract) Rated impulse voltages for electrical equipments, which are energised directly by a low-voltage system

Nominal voltage of the supply system <sup>1)</sup> based on IEC 60038 <sup>3)</sup>		Rated impulse voltage <sup>2)</sup>			
		Overvoltage category <sup>4)</sup>			
Three phase V	Single phase V	I V	II V	III V	IV V
	120-240	800	1 500	2 500	4 000
230/400	277/480	1 500	2 500	4 000	6 000
	400/690	2 500	4 000	6 000	8 000
	1 000	4 000	6 000	8 000	12 000

<sup>1)</sup> See Annex B for application to existing different low-voltage mains and their nominal voltages.  
<sup>2)</sup> Equipment with these rated impulse voltages can be used in installations in accordance with IEC 60364-4-44.  
<sup>3)</sup> The / mark indicates a four-wire three-phase distribution system. The lower value is the voltage line-to-neutral, while the higher value is the voltage line-to-line. Where only one value is indicated, it refers to three-wire, three-phase systems and specifies the value line-to-line.  
<sup>4)</sup> See 4.3.3.2.2 for an explanation of the overvoltage categories.

### F.4 DIN EN 60664-1 (VDE 0110-1), table F.4 (extract) Creepage distance for the avoidance of the failure by tracking

Voltage r.m.s. <sup>1)</sup>  V	Minimum creepage distances								
	Printed wiring material			Pollution degree					
	All material groups	All material groups except IIIb	All material groups	1			3		
				I	II	III	I	II	III <sup>2)</sup>
mm	mm	mm	mm	mm	mm	mm	mm	mm	mm
25	0,025	0,040	0,125	0,500	0,500	0,500	1,250	1,250	1,250
32	0,025	0,040	0,14	0,53	0,53	0,53	1,30	1,30	1,30
40	0,025	0,040	0,16	0,56	0,80	1,10	1,40	1,60	1,80
50	0,025	0,040	0,18	0,60	0,85	1,20	1,50	1,70	1,90
63	0,040	0,063	0,20	0,63	0,90	1,25	1,60	1,80	2,00
80	0,063	0,100	0,22	0,67	0,95	1,30	1,70	1,90	2,10
100	0,100	0,160	0,25	0,71	1,00	1,40	1,80	2,00	2,20
125	0,160	0,250	0,28	0,75	1,05	1,50	1,90	2,10	2,40
160	0,250	0,400	0,32	0,80	1,10	1,60	2,00	2,20	2,50
200	0,400	0,630	0,42	1,00	1,40	2,00	2,50	2,80	3,20
250	0,560	1,000	0,56	1,25	1,80	2,50	3,20	3,60	4,00
320	0,75	1,60	0,75	1,60	2,20	3,20	4,00	4,50	5,00
400	1,0	2,0	1,0	2,0	2,8	4,0	5,0	5,6	6,3
500	1,3	2,5	1,3	2,5	3,6	5,0	6,3	7,1	8,0
630	1,8	3,2	1,8	3,2	4,5	6,3	8,0	9,0	10,0
800	2,4	4,0	2,4	4,0	5,6	8,0	10,0	11,0	12,5
1000	3,2	5,0	3,2	5,0	7,1	10,0	12,5	14,0	16,0

<sup>1)</sup> This voltage is  
- for functional insulation, the working voltage,  
- for basic and supplementary insulation of the circuit energized directly from the supply mains (see 4.3.2.2.1), the voltage rationalized through Table F.3a or Table F.3b, based on the rated voltage of the equipment, or the rated insulation voltage,  
- for basic and supplementary insulation of systems, equipment and internal circuits not energized directly from the mains (see 4.3.2.2.2), the highest r.m.s. voltage which can occur in the system, equipment or internal circuit when supplied at rated voltage and under the most onerous combination of conditions of operation within equipment rating.  
<sup>2)</sup> Material group IIIb is no not recommended for application in pollution degree 3 above 630 V.

and the availability of the electrical equipment, e.g. switches in firm installations and devices for industrial use with continuing connection to the firm installation.

#### Overvoltage category II

Energy using electrical equipment, which is energised by a firm installation e.g. household appliances, portable tools and other domestic appliances as well as similar devices.

#### Overvoltage category I

Electrical equipment for the connection to electric circuits, in which measures are taken for the delimitation of the transient overvoltages to a suitable low value, e.g. devices with electronic circuits and appropriate protection level.

# Technical Information

## Degree of contamination

The micro environment determines the influence of the contamination on the isolation.

However the macro environment must be considered with the view of the micro environment.

Resources to achieve a reduction of the contamination on the regarded isolation can be planned by the effective employment of casings (housings), encapsulations or hermetic sealings.

The influence of the contamination is considered with the calculation of air and creepage distances by degrees of pollution.

Four degrees of contamination levels are defined for the micro environment:

### Contamination level 1

No contamination or only dry, non-conductive contamination occurs. The contamination has no influence;

### Contamination level 2

Only non-conductive contamination occurs. However, occasional temporary conductivity must be expected as a result of moisture condensation;

### Contamination level 3

Conductive contamination occurs; dry, non-conductive contamination which becomes conductive as a result of moisture condensation may also occur;

### Contamination level 4

Impurities in the form of conductive dust, rain or humidity result in permanent conductivity.

## Insulant

DIN EN 60664-1 (VDE 0110-1) divides the insulants according to their CTI values in four groups. These are:

- Insulant I:  $600 \leq CTI$
- Insulant II:  $400 \leq CTI < 600$
- Insulant IIIa:  $175 \leq CTI < 400$
- Insulant IIIb:  $100 \leq CTI < 175$

The check numbers of the tracking must be determined according to IEC 60112 at an examination body using test solution A. The check number of the tracking is used as a proof of the creepage characteristics of insulants.

**F.2** DIN EN 60664-1 (VDE 0110-1), table F.2 (extract)  
**Clearance for transient overvoltages**

Required impulse withstand voltage <sup>1) 5)</sup>	Minimum clearance in air up to 2 000 m above sea level		
	Case A Inhomogeneous field (see 3.15)		
	Pollution degree		
kV	1 mm	2 mm	3 mm
1,2	0,25	0,25	0,8 <sup>4)</sup>
1,5 <sup>2)</sup>	0,5	0,5	
2,0	1,0	1,0	1,0
2,5 <sup>2)</sup>	1,5	1,5	1,5
3,0	2,0	2,0	2,0
4,0 <sup>2)</sup>	3,0	3,0	3,0
5,0	4,0	4,0	4,0
6,0 <sup>2)</sup>	5,5	5,5	5,5
8,0 <sup>2)</sup>	8,0	8,0	8,0

<sup>1)</sup> This voltage is  
- for functional insulation, the maximum impulse voltage expected to occur across the clearance (see 5.1.5),  
- for basic insulation directly exposed to or significantly influenced by transient overvoltages from the low-voltage mains (see 4.3.3.3, 4.3.3.4.1 and 5.1.6), the rated impulse voltage of the equipment,  
- for other basic insulation (see 4.3.3.4.2), the highest impulse voltage that can occur in the circuit.

<sup>2)</sup> Preferred values as specified in 4.2.3.

<sup>4)</sup> The minimum clearances given for pollution degrees 2 and 3 are based on the reduced withstand characteristics of the associated creepage distance under humidity conditions (see IEC 60664-5).

<sup>5)</sup> For parts or circuits within equipment subject to impulse voltages according to 4.3.3.4.2, interpolation of values is allowed. However, standardization is achieved by using the preferred series of impulse voltage values in 4.2.3.

# Technical Information

## Rated cross section

The current carrying capacity depends not only on the terminal design, but also on the application of the terminals. The appropriate specifications for the devices, e.g. DIN EN 60335-1 (VDE 0700-1), should be taken into account. According to DIN EN 60999-1 / VDE 0609 part 1, the current cross section and respectively the rated connection ability of a connection refers to the wire cross section indicated by the manufacturer, to which determined thermal, mechanical and electrical requirements apply to. The relationship between rated connection abilities and diameters of the wires is represented in table 1. If nothing else is specified in the product standard, each connection point must be able to take up not only its rated cross section (rated connection ability) but also the next two lower cross sections. Connecting points must be able to take up unprepared wires. Regarded as unprepared wires are all cables stripped at their ends, whose form is adjusted before insertion or whose wires are twisted for the purpose of the solidification. In the USA and Canada an identification is used by leader sizes (AWG) instead of the cross section indicated in mm<sup>2</sup>.

**T1** DIN EN 60999-1, table 1 (extract)  
Relation between rated connection abilities and wires

Rated cross section	Theoretical diameter of the largest conductor						
	metric			AWG			
	solid		flexible	solid		flexible	
	single wire	multi-stranded wire		b) single wire	b) Class B multi-stranded wire	c) Class I, K, M multi-stranded wire	
mm <sup>2</sup>	mm	mm	mm	No.	mm	mm	mm
0,2	0,51	0,53	0,61	24	0,54	0,61	0,64
0,34	0,63	0,66	0,8	22	0,68	0,71	0,80
0,5	0,9	1,1	1,1	20	0,85	0,97	1,02
0,75	1,0	1,2	1,3	18	1,07	1,23	1,28
1,0	1,2	1,4	1,5	—	—	—	—
1,5	1,5	1,7	1,8	16	1,35	1,55	1,60
2,5	1,9	2,2	2,3 <sup>a)</sup>	14	1,71	1,95	2,08
4,0	2,4	2,7	2,9 <sup>a)</sup>	12	2,15	2,45	2,70
6,0	2,9	3,3	3,9 <sup>a)</sup>	10	2,72	3,09	3,36
10,0	3,7	4,2	5,1	8	3,34	3,89	4,32
16,0	4,6	5,3	6,3	6	4,32	4,91	5,73
25,0	—	6,6	7,8	4	5,45	6,18	7,26
35	—	7,9	9,2	2	6,87	7,78	9,02

NOTE The diameter of the largest solid and flexible wire is based on Table 1 according to IEC 60228A and IEC 60344 and for AWG conductors on ASTM B 172-71 [4], ICEA-Publication S-19-81 [5], ICEA-Publication S-66-524 [6] and ICEA-Publication S-66-516 [7].

<sup>a)</sup> Information only for flexible wires in class 5 of IEC 60228A.  
<sup>b)</sup> Nominal + 5 %.  
<sup>c)</sup> Largest diameter for each of the three classes I, K, M + 5 %.

## Current carrying-capacity

Technical data state a maximum rated current at which no thermal damage or malfunctions occur, if a certain ambient temperature and rated cross-section is provided. The rated current is a current which the terminal or connector can carry simultaneously at all contacts without exceeding the maximum permissible temperature limit.

Appropriate test currents are applied to the rated cross sections (see table T2). Depending on the connection type, the maximum permissible heating of the clamping unit is limited to 45 K (acc. to DIN 60998-1, Temperature Rise Test for PCB Connectors) and to 30 K (acc. to DIN 60512-5-1, Temperature Rise Test for Plug Connectors) Based on the results of the temperature rise test acc. to DIN EN 60512-5-2 and the rated cross-section, a current carrying curve (base curve) is generated under consideration of the upper temperature limit for the insulating material and depending on the ambient temperature.

This base curve is used to determine the current carrying capacity of PCB connectors. For plug connectors, the base curve is corrected by factor 0.8 (derating curve). The permissible current carrying capacity not only depends on the terminal design but also the final application of the terminal. The corresponding equipment specifications, e.g. DIN EN 60335-1 (VDE 0700-1) must be observed.

**T2** DIN EN 60998-1, table 2 (extract)  
Relation between rated connection abilities and testing current

Rated Cross-section	Load capacity
mm <sup>2</sup>	A
0,2	4
0,34	5
0,5	6
0,75	9
1	13,5
1,5	17,5
2,5	24
4	32
6	41
10	57
16	76
25	101
35	125



# Index

Product	Page	Product	Page	Product	Page
110-M-225-THR	55	950-D-SMD-DS	25	Content	3
110-M-221-THR	54	950-THR	31	Coding Systems	58
110-M-221-SMD	48			Household Appliance	6
110-M-226-SMD	49	970-THR	32	Marking	59
110-M-211-THR	52			Moulding colours	61
110-M-216-SMD	47	971-SLT-SMD	38	Overview	4
110-M-211-SMD	46	971-SLR-THR	42	Packaging	60
110-M-215-THR	53	971-SLR-SMD-1,1	36	RoHS	7
		971-SLR-SMD-1,3	37	Screws	61
120-M-221-SMD	51	971-SLR-THR-1,1	43	Soldering processes	62
120-M-211-SMD	50	971-SLR-THR-1,3	44	Symbols on our data sheets	8
120-M-211-THR	56			The WECO Group	5
120-M-221-THR	57	974-D-SMD-DS	26	Technical Information	63-65
120-K	58				
		BST-.. (Marking strips)	59		
140-A-111-THR	30				
140-A-SMD	23				
140-A-126-SMD	24				
210-A-111-THR	27				
210-A-SMD	20				
210-A-126-SMD	21				
802-A-111-SMD	11				
803-A-111-SMD	12				
804-A-111-SMD	13				
830-A-111-SMD	14				
830-A-111-THR	16				
830-A-121-THR	17				
830-A-121-SMD	15				
930-D-SMD-DS	22				
930-THR	28				
931-SLR-THR	39				
931-SLR-SMD-1,1	34				
931-SLR-SMD-1,3	35				
931-SLR-THR-1,1	40				
931-SLR-THR-1,3	41				
931-SLT-SMD-1,1-L4	18				
934-THR-DS	29				

## Catalogue overview

### Electronic

- 1** Pitch 3,5 mm
- 2** Pitch 5 mm
- 3** Pitch 5,08 mm
- 4** Pitch 7,5 mm
- 5** Pitch >10 mm
- 6** SMD & THR

### Electrical

- 7** Europe type connectors
- 8** Tab connectors & Screw connectors
- 9** Unisolated terminals & ceramic components

# Your Contact

## **NORTH AMERICA**

*GLOBAL HEADQUARTER*  
WECO Electrical Connectors Inc.  
18 050 Trans-Canada Highway  
Kirkland, QC Canada H9J 4A1  
Phone: +1 514 694-9136  
Fax: +1 514 694-0956  
info@wecoconnectors.com  
www.wecoconnectors.com

## **LATIN AMERICA**

WECO de México SA CV  
Carretera a Morelia 3583-B  
Tlajomulco de Zuñiga  
Guadalajara, Jalisco  
Fraccionamiento Los Gavilanes  
Codigo Postal: 45645, México  
Phone: +52 33 3684 9066  
Fax: +52 33 3684 9066  
info@wecoconnectors.com  
www.wecoconnectors.com

## **BRAZIL**

WECO do Brasil LTDA.  
Rod. BR-116, 12.757 - Vila Fanny  
Curitiba, PR CEP-81690-200  
Phone: +55 41-3278-9720  
Phone: +55 41-3278-9721  
Phone: +55 41-3278-9717  
info@wecoconnectors.com  
www.wecoconnectors.com

## **EMEIA**

WECO Contact GmbH  
Donaustrasse 15  
63452 Hanau, Germany  
Phone: +49 6181 105 -145  
Fax: +49 6181 105 -720  
vertrieb@wecogroup.com  
www.wecogroup.com

## **ASIA PACIFIC**

WECO Electrical Connectors Ltd.  
Room 1105, New Commerce  
Centre  
19 On Sum Street, Shatin  
New Territory, Hong Kong  
Phone: +852 2636 6252  
Fax: +852 2559 3161  
info@wecoconnectors.com  
www.wecoconnectors.com

## **ASIA PACIFIC**

WECO Electrical (Shenzhen) Ltd.  
Room 11-G, Block A, Huaqiang  
Square, Huaqiang North Road,  
Futian,  
518031 Shenzhen, P.R. China  
Phone: +86 755 8280 7672 -0  
Fax: +86 755 8280 7674  
info@wecoconnectors.com  
www.wecoconnectors.com