

152-A-221

PCB connector

Screw connection, wire entrance vertical to PCB, interlocking, with test pick-off

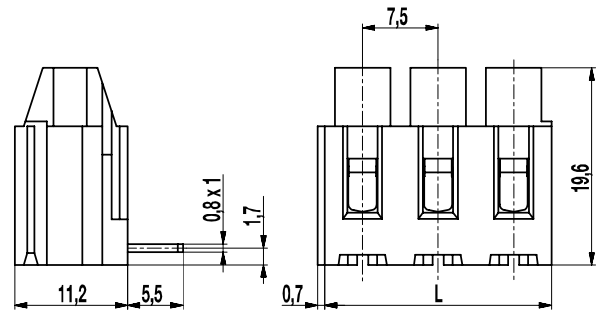

GENERAL INFORMATION

Pitch	7,5 mm
No. of poles	2 + 3

TECHNICAL DATA

Clamping Range	solid / stranded / AWG		
	0,14 - 4 mm ² / 0,14 - 2,5 mm ² / 26 - 14 AWG		
Rated Cross Section	2,5 mm ²		
Wire Stripping Length	7,5 mm ± 0,5 mm		
Overvoltage Category	III	III	II
Pollution Severity Level	3	2	2
Rated Voltage	400 V	630 V	1000 V
Rated Impulse Voltage	6 kV	6 kV	6 kV
Rated Insulation Voltage	750 V acc. to EN 60998-1		
Rated Current	24 A		
Hole in PCB	ø 1,3 mm		
Torque	0,5 Nm		

APPROVALS

	Current [A]	Voltage [V]	Group	AWG	[Nm]
	20 [1]	300	B	22-10 [2]	0,51
	10	300	D	22-10 [2]	0,51
	20	300	B	26 - 10	0,51
	10	300	D, E	26 - 10	0,51

[1] 20 A max for factory-wiring only

[2] Wire sizes No. 26 - 24 AWG for factory-wiring only

MATERIAL

Moulding	PA, grey, V-0
Comparative Tracking Index	CTI ≥ 600
Insulating Group	I
Temperature Range	-40°C up to 100°C
Terminal body	Nickel plated brass
Pressure clamp	Copper alloy, tin plated
Screw	M3; zinc plated steel, blue passivated
Solder pin	1,0 x 0,8 mm; copper alloy, tin plated

OPTIONS / ACCESSORIES

- Consecutive numbering
- Special marking according to drawing
- Self-adhesive marking strip BST-7,50
- Version with empty poles
- Connected to larger number of poles

CONFIGURATIONS

Poles	Item	Article number	Length (L)	Packaging	PU
2	152-A-221/02	20.801.702	15,00 mm	Box	200
3	152-A-221/03	20.801.703	22,50 mm	Box	100

