

328

Socket terminal strip
Screw connection

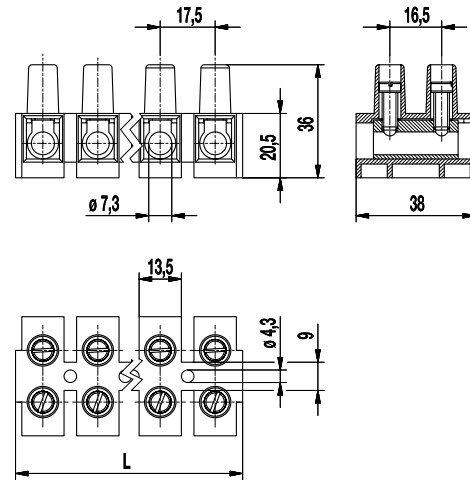

GENERAL INFORMATION

Pitch	17,5 mm
No. of poles	1 - 12

TECHNICAL DATA

Clamping Range	<i>solid / stranded / AWG</i> 6 - 25 mm ² / 6 - 16 mm ² / 10 - 4 AWG
Rated Cross Section	25 mm ²
Wire Stripping Length	13 mm
Rated Insulation Voltage	750 V acc. to EN 60998-1
Rated Current	101 A
Torque	2,6 Nm

APPROVALS

	Current [A]	Voltage [V]	Group	AWG	[Nm]
	85	600	B,C	10 - 4	2,6

MATERIAL

Moulding	PA, black, UL 94, V-2
Comparative Tracking Index	CTI 1 (400-599)
Temperature Range	-30°C up to 120°C
Terminal body	Nickel plated brass
Screw	M5; Zinc plated steel, clear passivated

OPTIONS / ACCESSORIES

- Consecutive numbering
- Special marking according to drawing
- Other colours available upon request

CONFIGURATIONS

Version	Poles	Item	Article number	Length (L)	PU
Standard	12	328/12	22.825.101	210,00 mm	15

