

976-T(-DS)

PCB connector

Screw connection 45°-angle to PCB, interlocking

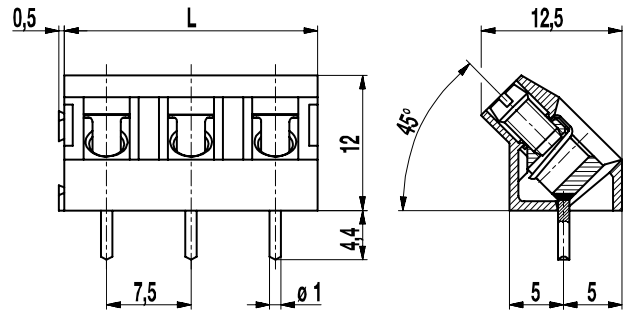

GENERAL INFORMATION

Pitch	7,5 mm
No. of poles	2 + 3

TECHNICAL DATA

Clamping Range	solid / stranded / AWG		
without wire protector	1 - 6 mm ² / 1 - 2,5 mm ² / 16 - 12 AWG		
with wire protector	0,75 - 4 mm ² / 0,75 - 2,5 mm ² / 18 - 12 AWG		
Rated Cross Section	2,5 mm ²		
Wire Stripping Length	6,5 mm ± 0,5 mm		
Overvoltage Category	III	III	II
Pollution Severity Level	3	2	2
Rated Voltage	400 V	630 V	1000 V
Rated Impulse Voltage	6 kV	6 kV	6 kV
Rated Insulation Voltage	750 V acc. to EN 60998-1		
Rated Current	24 A		
Hole in PCB	ø 1,3 mm		
Torque	0,5 Nm		

APPROVALS

	Current [A]	Voltage [V]	Group	AWG	[Nm]
	15	300	B	22-12 [1]	0,51
	20	300	B	26 - 12	0,51
	10	300	D, E	26 - 12	0,51

[1] Min No. 26 AWG for factory-wiring only

MATERIAL

Moulding	PA, grey, V-0
Comparative Tracking Index	CTI ≥ 600
Insulating Group	I
Temperature Range	-40°C up to 100°C
Terminal body	Tin plated brass
Screw	M3; zinc plated steel, clear passivated
Solder pin	ø 1 mm; tin plated copper
Wire protector	Tin plated tin bronze

OPTIONS / ACCESSORIES

- Marking according to customer requirement
- Self-adhesive marking strip BST-7,50
- Longer solder pins up to 75 mm
- Special wire protector for very thin conductors

CONFIGURATIONS

Poles	Item	Article number	Item	Article number	Length (L)	Packaging	PU
2	976-T/02	10.874.232	976-T-DS/02	20.874.232	15,00 mm	Box	250
3	976-T/03	10.874.233	976-T-DS/03	20.874.233	22,50 mm	Box	250

